

- Large - Black
大焦点 - 黑色
- Small - White
小焦点 - 白色
- Stand - By
备用
- Frame or Chasis
框架或底盘
- X-Ray Tube
X 射线管
- Radiation Filter or Filtration
辐射过滤器或过滤

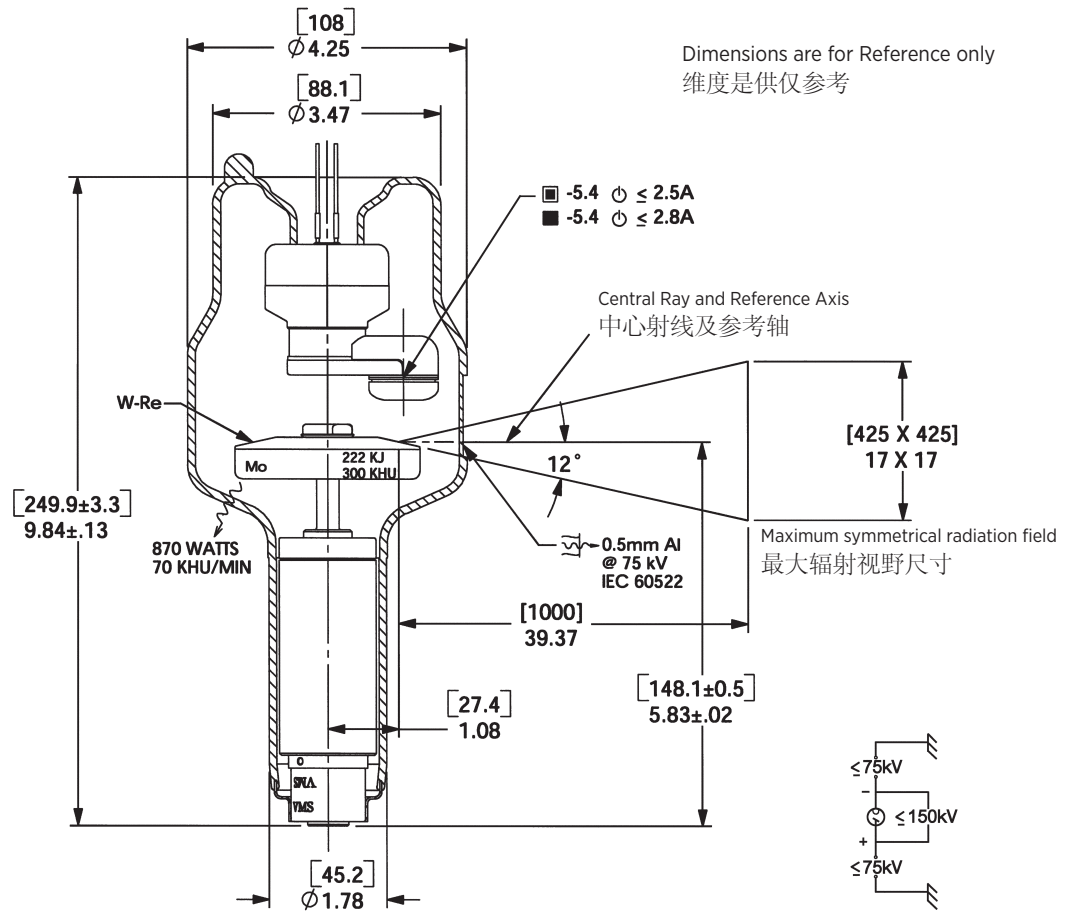

Note: Document originally drafted in the English language.
注释：文件最初用英语起草。

Product Description

The A-132 is a 2.8" (71mm) 150 kV, 222 kJ (300 kHU) maximum anode heat content, rotating anode insert. This insert is specifically designed for heavy duty general radio-graphic and fluoro/spotfilm procedures. The insert features a 12° rhenium-tungsten molybdenum target and is available with the following nominal focal spot:

0.6 - 1.2
IEC 60336

Nominal Anode Input Power

Small - 32 kW IEC 60613
Large - 76 kW IEC 60613

For the equivalent anode input power of 80 Watts

产品说明

A-132 是一款具有 2.8" (71 mm) 靶盘, 150 kV、222 kJ (300 kHU) 最大阳极热容量的旋转阳极 X 射线管芯。此管芯经专门设计, 可适用于大功率普通放射成像和荧光分光光度计/点片程序。该管芯的靶盘结构为 12° 靶角, 铼钨钼合金靶材, 可提供下列尺寸的标称焦点:

0.6 - 1.2
IEC 60336

标称阳极输入功率
小焦点 - 32 kW IEC 60613
大焦点 - 76 kW IEC 60613
适用于 80 瓦的等效阳极 输入功率

3 Ø 恒定电压 

50 Hz

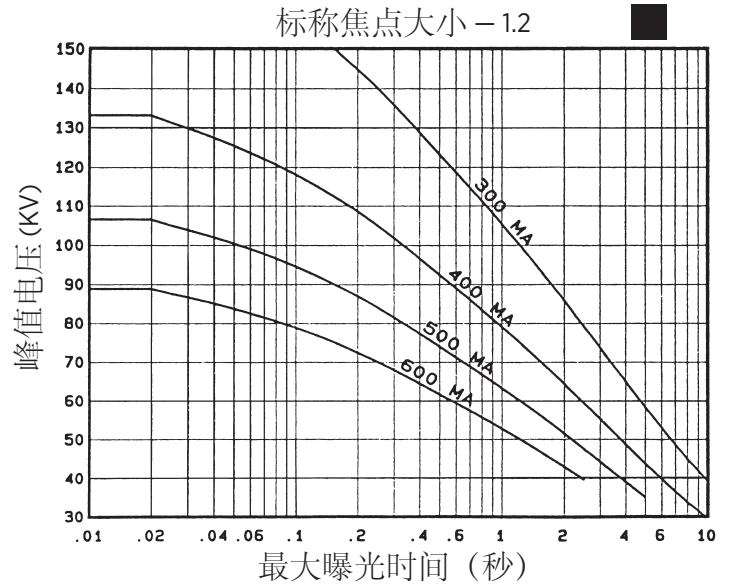
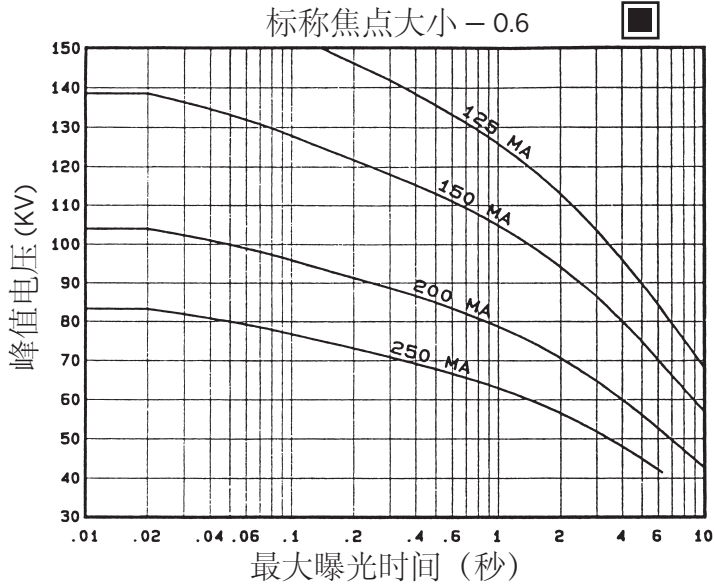

60 Hz

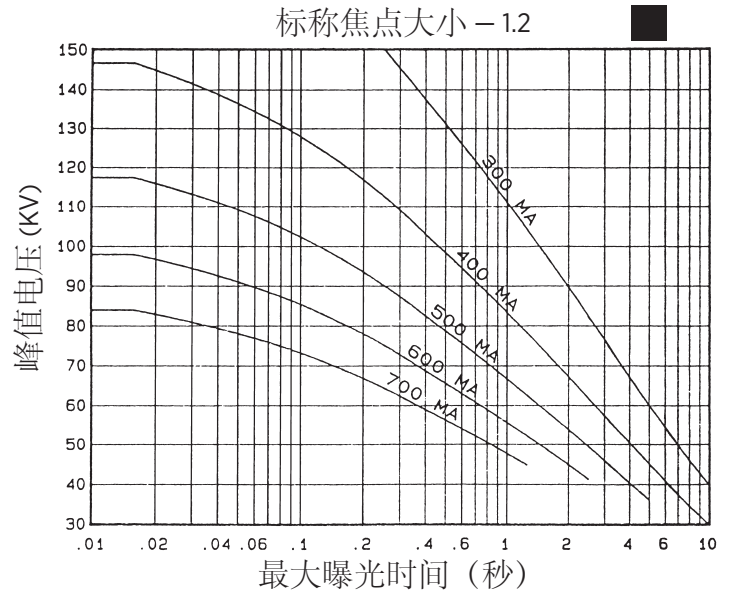
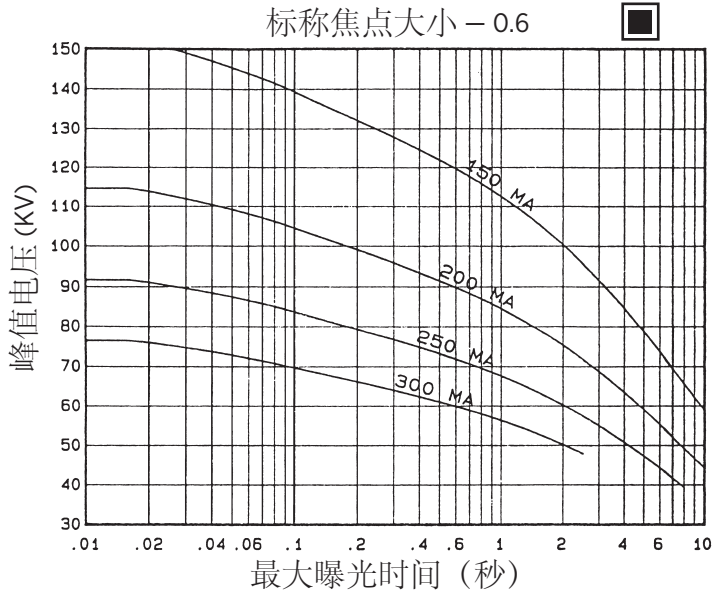

Nominal anode input power for the anode heat content 40%. IEC 60613

阳极热容量 40% 的标称阳极输入功率。IEC 60613

3 Ø 恒定电压 

150 Hz

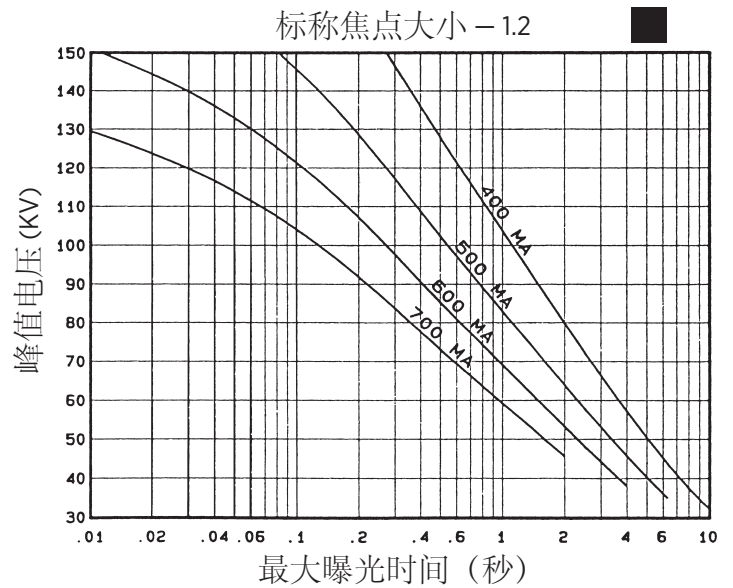
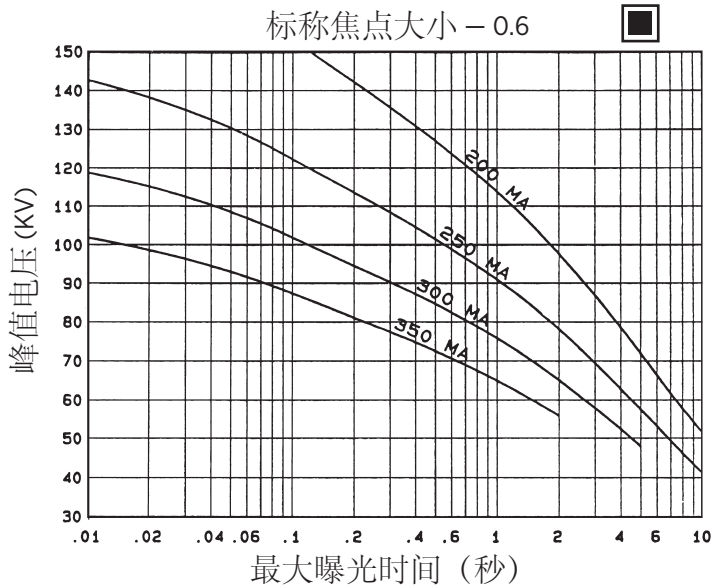

180 Hz

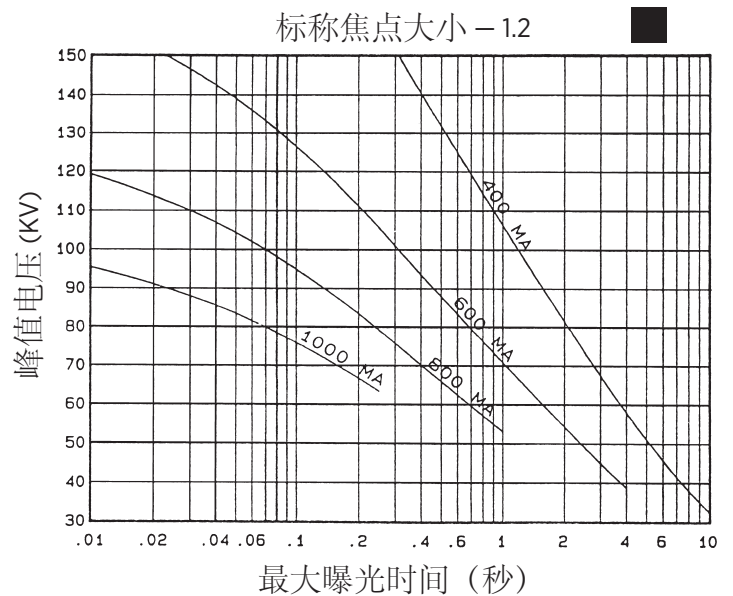
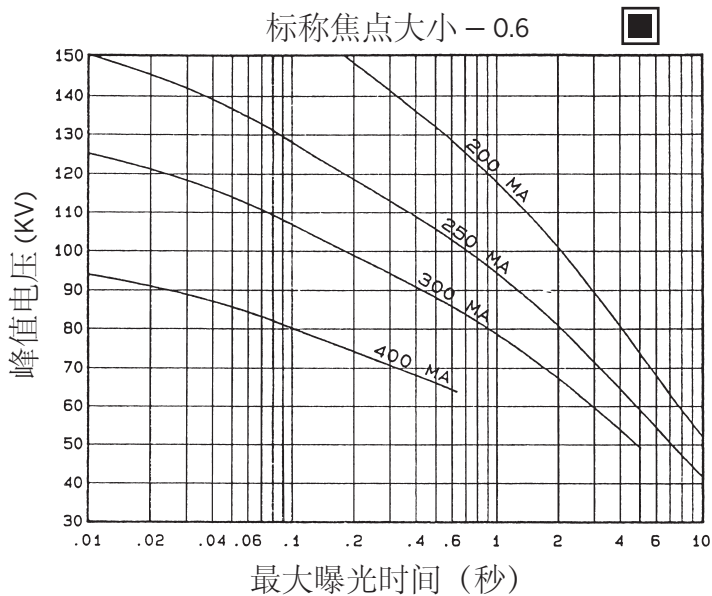

Nominal anode input power for the anode heat content 40%. IEC 60613

阳极热容量 40% 的标称阳极输入功率。IEC 60613

SERIAL LOAD RATINGS HOW TO USE SERIAL LOAD RATING CHARTS

General: Serial Radiography puts a severe demand on the x-ray tube due to the large number of exposures made in rapid succession. Intervals between exposures are fixed and so short that it is not possible for the anode track to cool to any extent during the exposure series. Therefore, the temperature of the anode track increases from exposure to exposure. The kW values used in the angiographic charts have been determined to prevent damage to the anode. The angiographic rating charts are usable to 100% anode heat storage. Exceeding 100% anode heat storage will cause anode track erosion with high risk of tube destruction.

Definition of Terms

Number of Exposures in Series: The number of exposures made in succession or the number of exposures made during one contrast injection.

Exposure Rate: The number of exposures made per second. For a series of exposures where the exposure rate changes, it must be assumed that all exposures will be made at the maximum rate. For example, if during a series 10 exposures will occur at one per second and 30 exposures at 4 per second use the kW ratings in the 40 exposure column at 4 per second rate.

Exposure Time: Time in seconds of each exposure.

USING THE CHARTS:

Determine the number of exposures in Series: With cut film angiography the number of exposures are known, however in Digital Angiography the number of exposures commonly are not known. When determining the number of exposures, assume worst case or past history.

Note: Most angiographic x-ray tubes fail from under-estimating the number of exposures made in a series.

Determine kW of each exposure in Series: Referring to chart –find block under “Number of Exposures in Series” that is greater than or equal to expected number of exposures in Series. On left side directly opposite this block under “Exposure Rate per Second” column, select maximum rate per second that will be used for the exposure series. At the intersection of exposure rate and exposure time in seconds, find maximum kW allowed for each exposure.

kW = pkV x mA: The kW of the exposure can be any combination of mA and pkV allowed by the Radiographic and Filament Emission charts.

For Example: 80 pkV and 500 mA = 40 kW

Example: From chart A-132 150/180 Hz 3 Phase
1.2 Focal Spot, determine kW allowed with following known factors.
Maximum number of exposures 40
Exposure time .050 second (50 milliseconds)
Maximum Exposures per second 4

From chart find 40 exposure block. On left side directly opposite this block under “Exposure Rate per Second” column, select 4 exposures per second. Find .050 seconds at top of chart. At intersection of exposure rate line and exposure time, find 43.5 kW.

连续装载规定值 如何使用连续负载额定率图

概述：因为需要快速进行大量曝光，连续放射成像对 X 射线管提出了严格的要求。曝光的间隔是固定的，因为非常短，所以阳极磁道在连续曝光的过程中不可能冷却到任何程度。所以，阳极磁道的温度随着曝光次数的增加而升高。为了防止损坏阳极，血管造影图中使用的功率值经过了确认。血管造影额定功率图适用于 100% 的阳极热容量。超过 100% 的阳极热容量将导致阳极磁道腐蚀，且很容易损坏射线管。

术语定义

连续曝光次数：连续曝光次数或在一个造影剂注射期间进行的曝光次数。

曝光速度：每秒进行的曝光次数。对于曝光速度变化的连续曝光，必须假设所有曝光都将以最高的速度进行。例如，如果连续曝光时，10 次曝光将每秒发生一次，而 30 次的曝光每秒 4 次，则使用每秒 4 次速度时 40 次曝光栏中的额定功率。

曝光时间：每次曝光的时间（秒）。

使用图表：

确定连续曝光次数：对于单张胶片血管造影术，曝光次数都是已知的，但是在数字化血管造影术中，曝光次数往往都是不知道的。确定曝光次数时，假定最坏的情况或根据以往的经验。

注释：大多数血管造影 X 射线管的故障是由于低估了连续曝光次数。

确定连续曝光中每次曝光的功率 (kW)：参考图，在“连续曝光次数”下找到大于等于期望的连续曝光次数的区域。在左侧直接面对这块区域的“每秒的曝光速度”栏中，选择将用于该曝光序列的每秒最高速度。在曝光速率和曝光时间（秒）的交叉点处，找到每次曝光允许的最大功率值 (kW)。

kW = pkV x mA: 曝光的功率可以是放射成像和灯丝发射 图表允许的 mA 与 pkV 的任一组合。

例如： 80 pkV x 500 mA = 40 kW

例如： 从图 A-132 150/180 Hz 3 相
1.2 焦点中，用以下已知的系数确定允许的功率 (kW)。
最大曝光次数 40
曝光时间 0.050 秒 (50 毫秒)
每秒最大曝光次数 4

从图中找到 40 曝光区。在左侧正对这块的 “每秒曝光速度”栏，选择每秒 4 次曝光。在图顶部找到 0.050 秒。在曝光速度行与曝光时间的交叉点处，找到 43.5 kW。

0.6 Focal Spot 3Ø 12 Degrees 150/180 Hz
0.6 焦点 3Ø 12 度 150/180 Hz

每秒曝光速度	射线管负载 (kW), 作为该连续曝光中单独放射成像的曝光时间 (秒) 函数															连续曝光次数
	.010	.020	.030	.040	.050	.060	.080	.100	.120	.140	.160	.180	.200	.225	.250	
1	295	281	270	261	253	246	233	222	212	204	197	190	184	177	171	20
2	294	279	267	258	249	241	228	216	206	197	190	183	176	169	163	
3	293	277	265	254	245	237	223	211	200	191	183	176	0.0	0.0	0.0	
4	292	275	262	251	242	233	218	205	194	185	0.0	0.0	0.0	0.0	0.0	
8	288	268	253	240	228	218	0.0	0.0	0.0	0.0	0.0	0.0	0.0	0.0	0.0	
15	282	258	237	222	0.0	0.0	0.0	0.0	0.0	0.0	0.0	0.0	0.0	0.0	0.0	
30	271	241	0.0	0.0	0.0	0.0	0.0	0.0	0.0	0.0	0.0	0.0	0.0	0.0	0.0	
1	290	272	258	246	235	226	210	196	185	175	166	153	138	122	110	40
2	289	270	255	242	231	222	205	191	179	169	160	152	138	122	110	
3	287	268	252	239	227	217	200	186	174	163	154	146	0.0	0.0	0.0	
4	286	265	249	236	224	213	196	181	168	158	0.0	0.0	0.0	0.0	0.0	
8	282	258	239	223	210	199	0.0	0.0	0.0	0.0	0.0	0.0	0.0	0.0	0.0	
15	275	246	223	205	0.0	0.0	0.0	0.0	0.0	0.0	0.0	0.0	0.0	0.0	0.0	
30	262	227	0.0	0.0	0.0	0.0	0.0	0.0	0.0	0.0	0.0	0.0	0.0	0.0	0.0	
1	285	263	246	232	220	209	191	176	153	131	115	102	92	81	73	60
2	284	261	244	229	216	205	187	171	153	131	115	102	92	81	73	
3	282	259	241	226	213	201	182	167	153	131	115	102	0.0	0.0	0.0	
4	281	257	238	223	209	198	178	163	150	131	0.0	0.0	0.0	0.0	0.0	
8	276	249	228	211	196	184	0.0	0.0	0.0	0.0	0.0	0.0	0.0	0.0	0.0	
15	269	237	212	193	0.0	0.0	0.0	0.0	0.0	0.0	0.0	0.0	0.0	0.0	0.0	
30	256	218	0.0	0.0	0.0	0.0	0.0	0.0	0.0	0.0	0.0	0.0	0.0	0.0	0.0	
1	280	256	236	221	207	195	172	138	115	98	86	76	69	61	55	80
2	279	253	234	217	203	191	172	138	115	98	86	76	69	61	55	
3	278	251	231	214	200	188	168	138	115	98	86	76	0.0	0.0	0.0	
4	276	249	228	211	197	184	164	138	115	98	0.0	0.0	0.0	0.0	0.0	
8	271	241	218	200	185	172	0.0	0.0	0.0	0.0	0.0	0.0	0.0	0.0	0.0	
15	264	230	203	183	0.0	0.0	0.0	0.0	0.0	0.0	0.0	0.0	0.0	0.0	0.0	
30	250	210	0.0	0.0	0.0	0.0	0.0	0.0	0.0	0.0	0.0	0.0	0.0	0.0	0.0	
1	276	248	227	210	195	183	138	110	92	79	69	61	55	49	44	100
2	275	246	224	207	192	179	138	110	92	79	69	61	55	49	44	
3	273	244	222	204	189	176	138	110	92	79	69	61	0.0	0.0	0.0	
4	272	242	219	201	186	173	138	110	92	79	0.0	0.0	0.0	0.0	0.0	
8	267	234	210	190	174	161	0.0	0.0	0.0	0.0	0.0	0.0	0.0	0.0	0.0	
15	259	223	195	174	0.0	0.0	0.0	0.0	0.0	0.0	0.0	0.0	0.0	0.0	0.0	
30	246	203	0.0	0.0	0.0	0.0	0.0	0.0	0.0	0.0	0.0	0.0	0.0	0.0	0.0	
1	265	232	207	183	147	122	92	73	61	52	46	41	37	33	29	150
2	264	230	205	183	147	122	92	73	61	52	46	41	37	33	29	
3	263	228	202	182	147	122	92	73	61	52	46	41	0.0	0.0	0.0	
4	261	226	200	180	147	122	92	73	61	52	0.0	0.0	0.0	0.0	0.0	
8	256	218	191	170	147	122	0.0	0.0	0.0	0.0	0.0	0.0	0.0	0.0	0.0	
15	249	208	178	156	0.0	0.0	0.0	0.0	0.0	0.0	0.0	0.0	0.0	0.0	0.0	
30	235	189	0.0	0.0	0.0	0.0	0.0	0.0	0.0	0.0	0.0	0.0	0.0	0.0	0.0	
1	238	183	122	92	73	61	46	37	31	26	23	20	18	16	15	300
2	237	183	122	92	73	61	46	37	31	26	23	20	18	16	15	
3	236	183	122	92	73	61	46	37	31	26	23	20	0.0	0.0	0.0	
4	235	183	122	92	73	61	46	37	31	26	0.0	0.0	0.0	0.0	0.0	
8	230	183	122	92	73	61	0.0	0.0	0.0	0.0	0.0	0.0	0.0	0.0	0.0	
15	223	174	122	92	0.0	0.0	0.0	0.0	0.0	0.0	0.0	0.0	0.0	0.0	0.0	
30	211	159	0.0	0.0	0.0	0.0	0.0	0.0	0.0	0.0	0.0	0.0	0.0	0.0	0.0	

Note:
1. (kW) of Exposure Equals mA x kV.
For Example: 70 kV x 300 mA = 21 kW.
2. Exposures less than .010 seconds will have a kW rating same as .010 seconds.

注释:
1. 曝光功率 (kW) 等于 mA x kV。 例如: 70 kV x 300 mA = 21 kW。
2. 小于 0.010 秒的曝光将与 0.010 秒曝光具有相同的额定功率。

Nominal anode input power for the anode heat content 70%. IEC 60613

阳极热容量 70% 的标称阳极输入功率。 IEC 60613

1.2 Focal Spot 3Ø 12 Degrees 150/180 Hz
1.2 焦点 3Ø 12度 150/180 Hz

每秒曝光速度	射线管负载 (kW), 作为该连续曝光中单独放射成像的曝光时间 (秒) 函数															连续曝光次数
	.010	.020	.030	.040	.050	.060	.080	.100	.120	.140	.160	.180	.200	.225	.250	
1	72.9	66.9	62.4	58.7	55.5	52.7	48.1	44.3	41.2	38.5	34.4	30.6	27.5	24.4	22.0	20
2	72.2	65.8	61.0	57.0	53.7	50.8	46.0	42.1	38.8	36.1	33.8	30.6	27.5	24.4	22.0	
3	71.6	64.8	59.7	55.5	52.0	49.0	44.0	40.0	36.8	34.0	31.7	29.7	0.0	0.0	0.0	
4	71.1	64.0	58.7	54.4	50.8	47.7	42.2	38.2	34.9	32.2	0.0	0.0	0.0	0.0	0.0	
8	69.3	61.2	55.1	50.4	46.5	43.2	0.0	0.0	0.0	0.0	0.0	0.0	0.0	0.0	0.0	
15	66.9	57.5	50.7	45.6	0.0	0.0	0.0	0.0	0.0	0.0	0.0	0.0	0.0	0.0	0.0	
30	63.3	52.4	0.0	0.0	0.0	0.0	0.0	0.0	0.0	0.0	0.0	0.0	0.0	0.0	0.0	
1	69.9	62.0	56.1	51.5	47.7	44.4	34.4	27.5	22.9	19.6	17.2	15.3	13.8	12.2	11.0	40
2	69.2	60.9	54.8	50.0	46.1	42.8	34.4	27.5	22.9	19.6	17.2	15.3	13.8	12.2	11.0	
3	68.5	59.8	53.5	48.6	44.6	41.2	34.4	27.5	22.9	19.6	17.2	15.3	0.0	0.0	0.0	
4	67.9	59.0	52.6	47.6	43.5	40.1	34.4	27.5	22.9	19.6	0.0	0.0	0.0	0.0	0.0	
8	65.9	56.0	49.0	43.7	39.5	36.1	0.0	0.0	0.0	0.0	0.0	0.0	0.0	0.0	0.0	
15	63.0	52.0	44.5	39.0	0.0	0.0	0.0	0.0	0.0	0.0	0.0	0.0	0.0	0.0	0.0	
30	58.6	46.2	0.0	0.0	0.0	0.0	0.0	0.0	0.0	0.0	0.0	0.0	0.0	0.0	0.0	
1	67.1	57.8	51.1	45.8	36.7	30.6	22.9	18.3	15.3	13.1	11.5	10.2	9.2	8.1	7.3	60
2	66.4	56.8	49.9	44.7	36.7	30.6	22.9	18.3	15.3	13.1	11.5	10.2	9.2	8.1	7.3	
3	65.7	55.8	48.8	43.5	36.7	30.6	22.9	18.3	15.3	13.1	11.5	10.2	0.0	0.0	0.0	
4	65.2	55.0	47.9	42.5	36.7	30.6	22.9	18.3	15.3	13.1	0.0	0.0	0.0	0.0	0.0	
8	63.1	52.0	44.6	39.1	34.9	30.6	0.0	0.0	0.0	0.0	0.0	0.0	0.0	0.0	0.0	
15	60.1	48.1	40.4	34.8	0.0	0.0	0.0	0.0	0.0	0.0	0.0	0.0	0.0	0.0	0.0	
30	55.4	42.4	0.0	0.0	0.0	0.0	0.0	0.0	0.0	0.0	0.0	0.0	0.0	0.0	0.0	
1	64.6	54.2	45.8	34.4	27.5	22.9	17.2	13.8	11.5	9.8	8.6	7.6	6.9	6.1	5.5	80
2	63.9	53.2	45.8	34.4	27.5	22.9	17.2	13.8	11.5	9.8	8.6	7.6	6.9	6.1	5.5	
3	63.3	52.3	44.9	34.4	27.5	22.9	17.2	13.8	11.5	9.8	8.6	7.6	0.0	0.0	0.0	
4	62.7	51.5	44.0	34.4	27.5	22.9	17.2	13.8	11.5	9.8	0.0	0.0	0.0	0.0	0.0	
8	60.6	48.8	41.0	34.4	27.5	22.9	0.0	0.0	0.0	0.0	0.0	0.0	0.0	0.0	0.0	
15	57.6	45.0	37.2	31.7	0.0	0.0	0.0	0.0	0.0	0.0	0.0	0.0	0.0	0.0	0.0	
30	52.9	39.5	0.0	0.0	0.0	0.0	0.0	0.0	0.0	0.0	0.0	0.0	0.0	0.0	0.0	
1	62.3	51.0	36.7	27.5	22.0	18.3	13.8	11.0	9.2	7.9	6.9	6.1	5.5	4.9	4.4	100
2	61.6	50.1	36.7	27.5	22.0	18.3	13.8	11.0	9.2	7.9	6.9	6.1	5.5	4.9	4.4	
3	61.0	49.2	36.7	27.5	22.0	18.3	13.8	11.0	9.2	7.9	6.9	6.1	0.0	0.0	0.0	
4	60.4	48.6	36.7	27.5	22.0	18.3	13.8	11.0	9.2	7.9	0.0	0.0	0.0	0.0	0.0	
8	58.4	46.0	36.7	27.5	22.0	18.3	0.0	0.0	0.0	0.0	0.0	0.0	0.0	0.0	0.0	
15	55.5	42.4	34.5	27.5	0.0	0.0	0.0	0.0	0.0	0.0	0.0	0.0	0.0	0.0	0.0	
30	50.8	37.2	0.0	0.0	0.0	0.0	0.0	0.0	0.0	0.0	0.0	0.0	0.0	0.0	0.0	
1	57.2	36.7	24.4	18.3	14.7	12.2	9.2	7.3	6.1	5.2	4.6	4.1	3.7	3.3	2.9	150
2	56.6	36.7	24.4	18.3	14.7	12.2	9.2	7.3	6.1	5.2	4.6	4.1	3.7	3.3	2.9	
3	56.0	36.7	24.4	18.3	14.7	12.2	9.2	7.3	6.1	5.2	4.6	4.1	0.0	0.0	0.0	
4	55.5	36.7	24.4	18.3	14.7	12.2	9.2	7.3	6.1	5.2	0.0	0.0	0.0	0.0	0.0	
8	53.6	36.7	24.4	18.3	14.7	12.2	0.0	0.0	0.0	0.0	0.0	0.0	0.0	0.0	0.0	
15	50.9	36.7	24.4	18.3	0.0	0.0	0.0	0.0	0.0	0.0	0.0	0.0	0.0	0.0	0.0	
30	46.5	32.8	0.0	0.0	0.0	0.0	0.0	0.0	0.0	0.0	0.0	0.0	0.0	0.0	0.0	
1	36.7	18.3	12.2	9.2	7.3	6.1	4.6	3.7	3.1	2.6	2.3	2.0	1.8	1.6	1.5	300
2	36.7	18.3	12.2	9.2	7.3	6.1	4.6	3.7	3.1	2.6	2.3	2.0	1.8	1.6	1.5	
3	36.7	18.3	12.2	9.2	7.3	6.1	4.6	3.7	3.1	2.6	2.3	2.0	0.0	0.0	0.0	
4	36.7	18.3	12.2	9.2	7.3	6.1	4.6	3.7	3.1	2.6	0.0	0.0	0.0	0.0	0.0	
8	36.7	18.3	12.2	9.2	7.3	6.1	0.0	0.0	0.0	0.0	0.0	0.0	0.0	0.0	0.0	
15	36.7	18.3	12.2	9.2	0.0	0.0	0.0	0.0	0.0	0.0	0.0	0.0	0.0	0.0	0.0	
30	36.7	18.3	0.0	0.0	0.0	0.0	0.0	0.0	0.0	0.0	0.0	0.0	0.0	0.0	0.0	

Note:
1. (kW) of Exposure Equals mA x kV.
For Example: 70 kV x 300 mA = 21 kW.
2. Exposures less than .010 seconds will have a kW rating same as .010 seconds.

注释:
1. 曝光功率 (kW) 等于 mA x kV。 例如: 70 kV x 300 mA = 21 kW。
2. 小于 0.010 秒的曝光将与 0.010 秒曝光具有相同的额定功率。

Nominal anode input power for the anode heat content 70%. IEC 60613

阳极热容量 70% 的标称阳极输入功率。 IEC 60613

3 Ø 全波

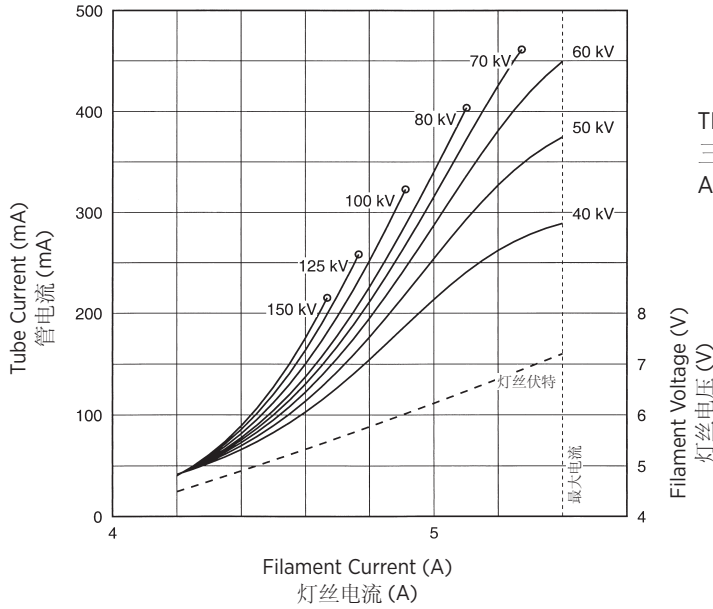

THREE PHASE EMISSION ($\pm .15$ A)
三相发射 ($\pm .15$ A)
A-132 0.6

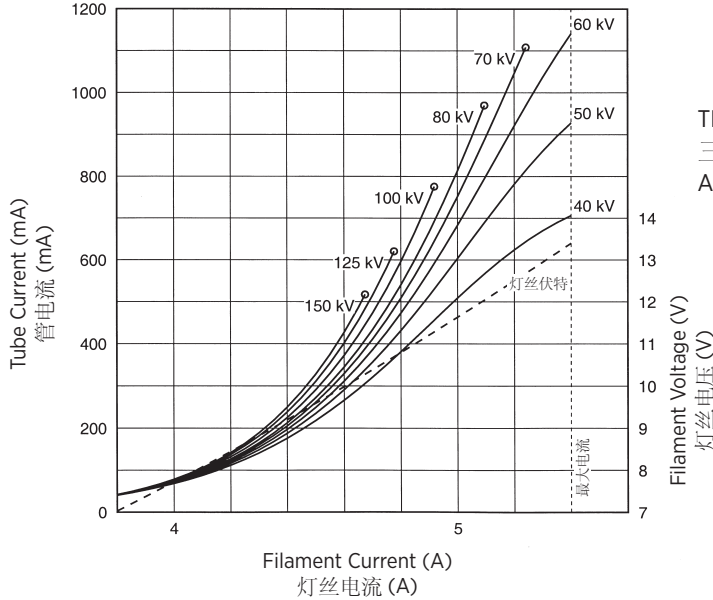

THREE PHASE EMISSION ($\pm .15$ A)
三相发射 ($\pm .15$ A)
A-132 1.2



Note:
When using these emission curves for trial exposures, refer to the power rating curves shown for maximum kV, tube emission, filament current, exposure time, and target speed.

注释:
当为试验曝光使用这些辐射曲线时, 请同时参考额定功率曲线中与最大管电压、管电流、灯丝电流、曝光时间和阳极靶转速相关的限制条件。

ANODE HEATING AND COOLING CURVES
阳极加热与冷却曲线

