

- Large - Black
大焦点 - 黑色
- Small - White
小焦点 - 白色
- Stand - By
备用
- Frame or Chasis
框架或底盘
- X-Ray Tube
X 射线管
- Radiation Filter or Filtration
辐射过滤器或过滤

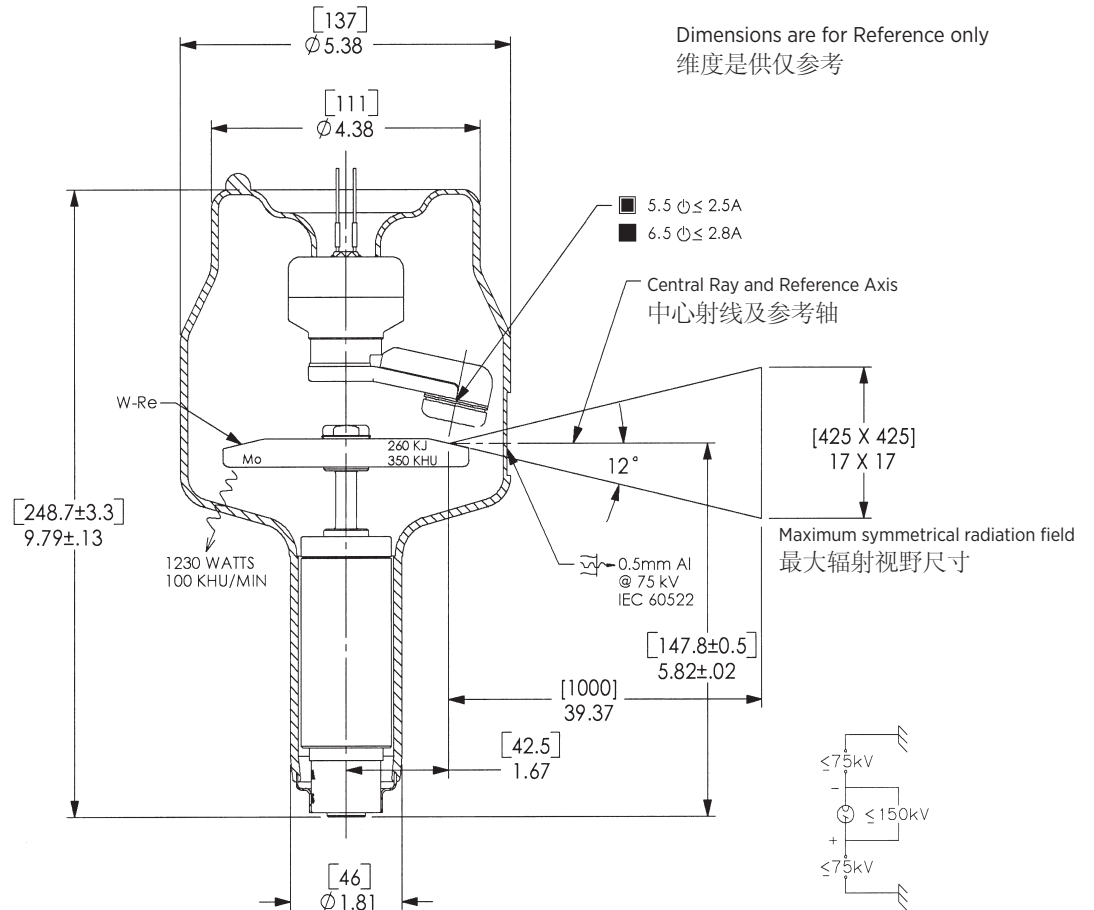

Note: Document originally drafted in the English language.

注释：文件最初用英语起草。

Product Description

The A-195 is a 4" (102 mm) 150 kV, 260 kJ (350 kHU) maximum anode heat content, rotating anode insert. This insert is specifically designed for general radiographic and fluoro/spotfilm procedures. The insert features a 12° tungsten rhenium molybdenum target and is available with the following nominal focal spot:

0.6 - 1.25
IEC 60336

Nominal Anode Input Power
Small - 40 kW IEC 60613
Large - 100 kW IEC 60613
For the equivalent anode input power of 125 Watts

产品说明

A-195 是一款具有 4" (102 mm) 靶盘, 150 kV `260 kJ (350 kHU) 最大阳极热容量的旋转阳极 X 线管芯。此管芯经专门设计, 可适用于普通放射成像和荧光分光光度计/点片程序。该管芯的靶盘结构为 12° 靶角, 铇钨钼合金靶材, 可提供下列尺寸的标称焦点:

0.6 - 1.25
IEC 60336

标称阳极输入功率
小焦点 - 40 kW IEC 60613
大焦点 - 100 kW IEC 60613
适用于 125 瓦的等效阳极输入功率

3 Ø 恒定电压

50 Hz

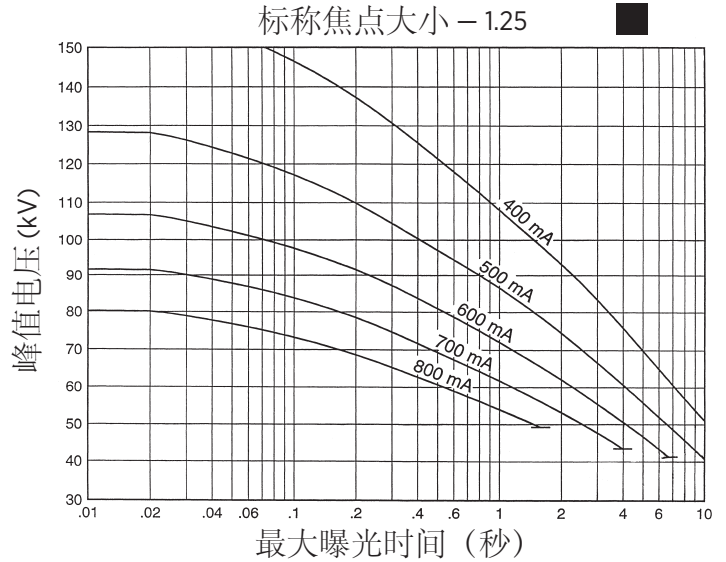
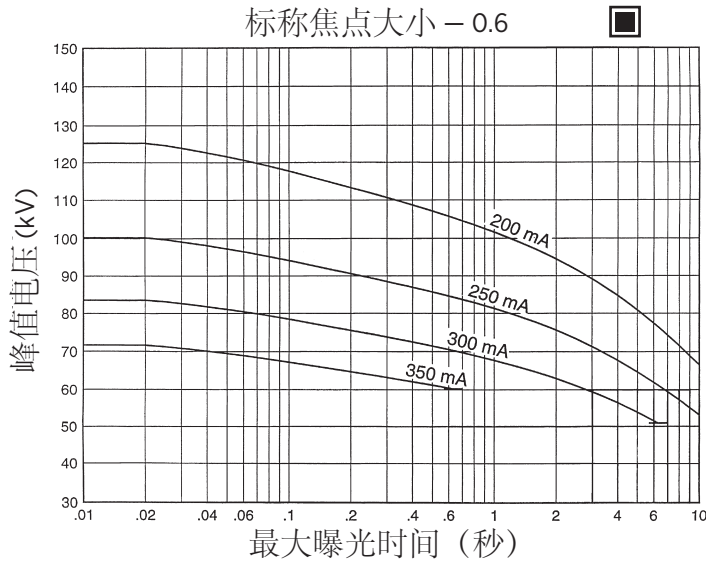

60 Hz

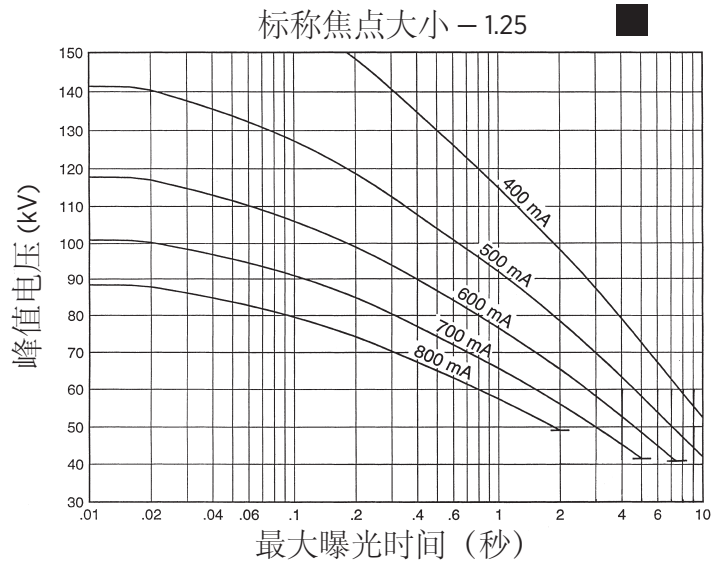
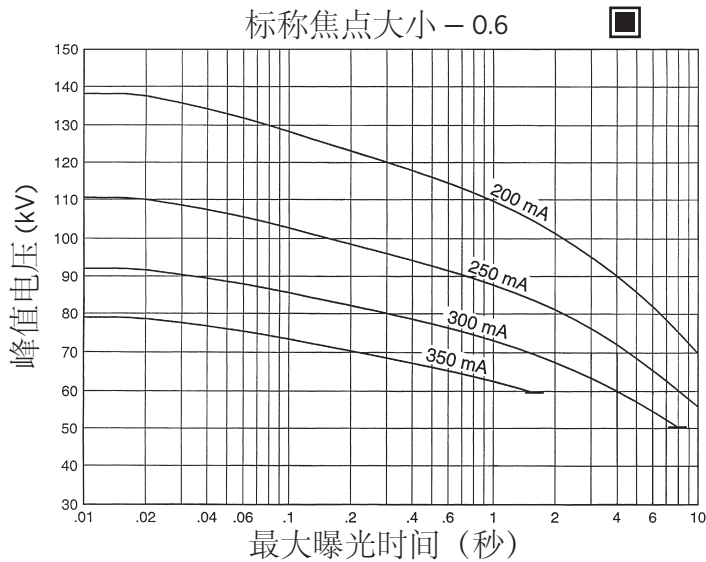

Nominal anode input power for the anode heat content 40%. IEC 60613

阳极热容量 40% 的标称阳极输入功率。IEC 60613

3 Ø 恒定电压

150 Hz

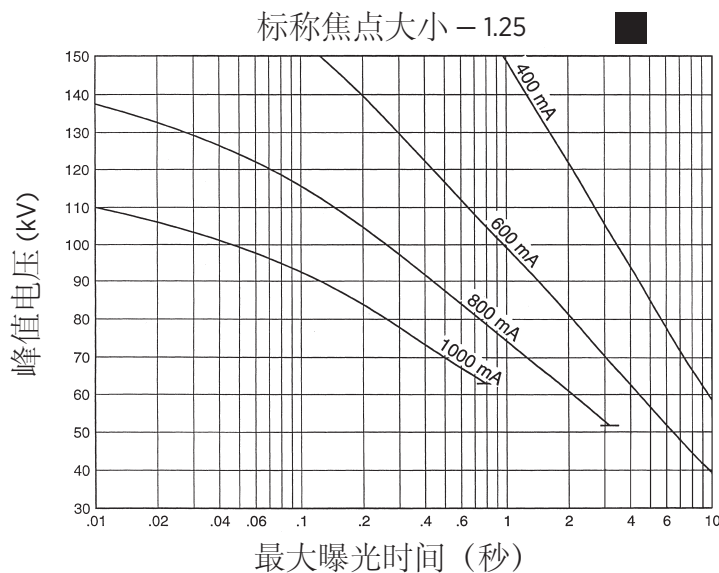
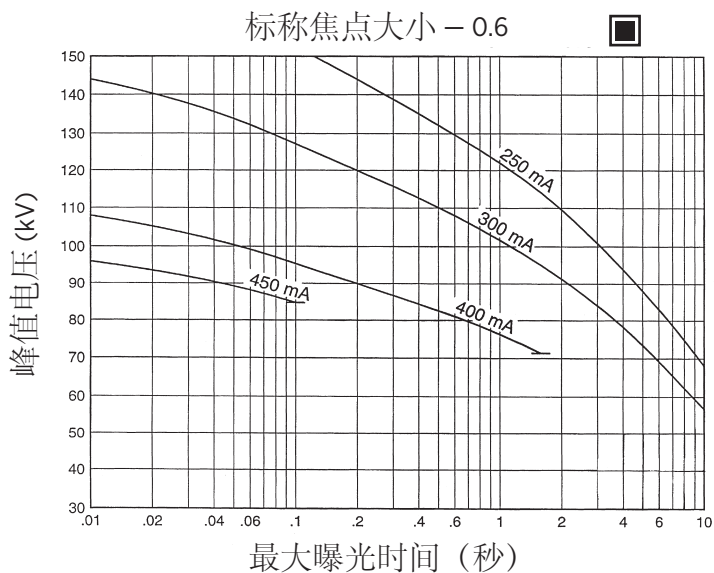

180 Hz

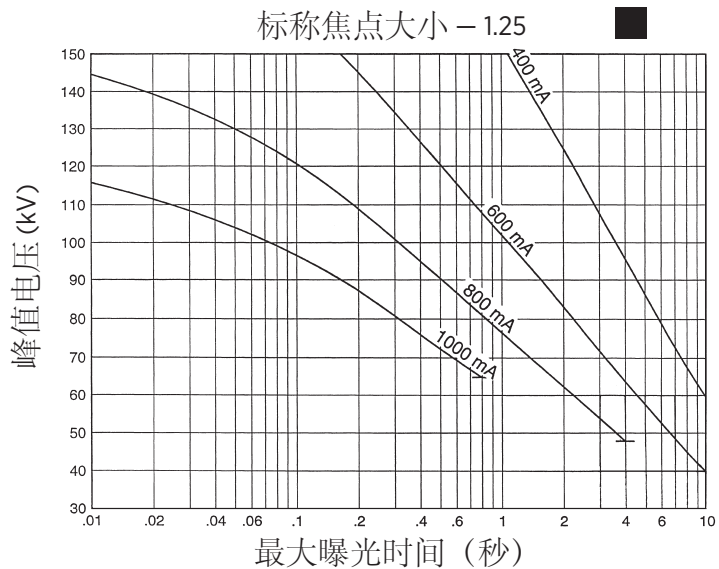
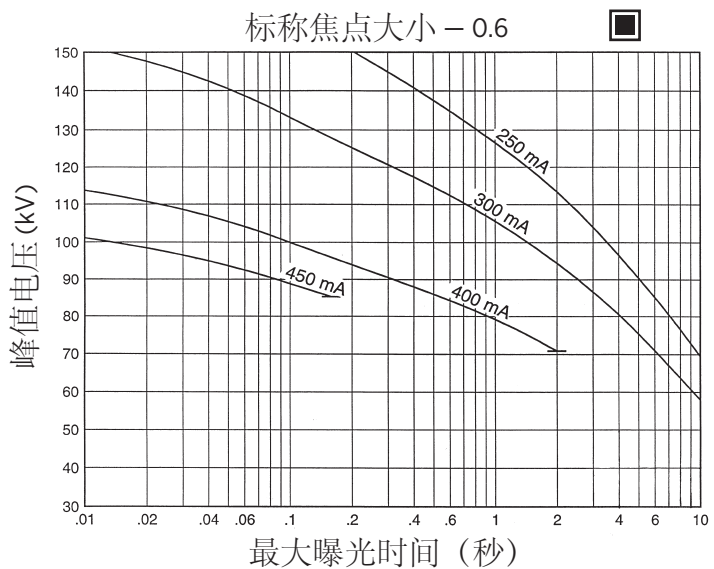

Nominal anode input power for the anode heat content 40%. IEC 60613

阳极热容量 40% 的标称阳极输入功率。IEC 60613

CINERADIOGRAPHIC RATINGS HOW TO USE CINERADIOGRAPHIC CHARTS

General: With the Cineradiographic rating chart we can determine the maximum allowable kW of the Cine pulse, or with a given kW determine maximum time in seconds the Cine run can progress.

The Most common way of using the charts is to determine maximum time of any expected Cine run and maximum duty factor. With a known duty factor and Cine run time kW can easily be determined.

Definition of Terms

Time in seconds: Total time of one Cine run, usually 5 to 12 seconds.

Duty Factor in Percent (DF%): Actual time during one second the x-ray tube is producing x-rays. If we select a 5 msec pulse width and 60 exposures per second the x-ray tube will be producing x-rays for a total of 250 msec each second or 25% of the time. The higher the DF number, the more load placed on the x-ray tube.

Peak Pulse Power: Peak energy in watts of any one Cine Pulse. Can be any combination of kV and mA allowed by Radiographic and Filament Emission curves.

Example: 80 kV at 400 mA equals

$$80,000 \text{ V} \times 0.4 \text{ A} = 32,000 \text{ W or } 32 \text{ kW}$$

USING THE CINE RATING CHARTS:

A-195 150/180 Hz 3 Phase 1.25 Focal Spot

Example: Determine maximum kW allowed with the following known factors:
 Maximum Pulse Width 2 msec
 Exposures per Second 60
 Maximum Cine Run Time 3 seconds

Calculate Duty Factor: (DF%)

$$DF\% = \frac{\text{Pulse Width (mSec)} \times \text{Frames per Second}}{10}$$

$$DF\% = \frac{2 \text{ msec} \times 60 \text{ exp/sec}}{10} = \frac{120}{10} = 12\%$$

Refer to Rating Chart A-195 150/180 Hz 3 Phase 1.25 Focal Spot:

At bottom of chart find 3 second line. Move vertically to intersection with 12% DF curve. Make a horizontal reference to left side of rating chart and note kW rating of 80 kW.

We now know each pulse during the cine run can have a maximum rating of 80 kW under conditions given in example.

kW = kV x mA. The kW of the exposure can be any combination of mA and kV allowed by the Radiographic and Filament Emission Charts.

The Cine rating charts are usable to 100% anode heat storage. The start of Cine run should be below 70% and heat storage. Exceeding 100% anode heat storage will cause anode track erosion with high risk of tube destruction.

电影摄影额定功率 如何使用电影摄影负载图

概述：利用电影摄影额定功率图，我们可以确定 Cine 脉冲的最大允许千瓦功率，或者用给定的千瓦值确定 Cine 运行的最长时间（秒）。

使用图表最常用的方法是确定任何预期的 Cine 运行的最长时间和最大占空系数。只要知道了占空系数和 Cine 运行时间，就可以轻松确定功率。

术语定义

时间（秒）：Cine 运行一次的总时间，通常为 5 到 12 秒钟。

占空系数 (DF%)：x 射线管生成 x 射线的一秒钟内的实际时间。如果我们选择 5 毫秒脉冲宽度和每秒 50 次曝光，x 射线管将会产生每秒总计 250 毫秒的 x 射线或 24% 的时间。DF 数越大，x 射线管上可承载的负载越高。

峰值脉冲功率：任一 Cine 脉冲的峰值能量 (W)。可以是放射成像和灯丝发射曲线允许的任一 kV 和 mA 组合。

例如：400 mA 时 80 kV 等于

$$80,000 \text{ V} \times 0.4 \text{ A} = 32,000 \text{ W 或 } 32 \text{ kW}$$

使用 CINE 额定功率图：

A-195 150/180 Hz 三相 1.25 焦点

例如：确定下列已知系数下的最大功率 (kW)：
 最大脉冲宽度 2 毫秒
 每秒曝光次数 60
 最长 Cine 运行时间 3 秒

计算占空系数：(DF%)

$$DF\% = \frac{\text{脉冲宽度 (毫秒)} \times \text{每秒的帧数}}{10}$$

$$DF\% = \frac{2 \text{ 毫秒} \times 60 \text{ 次曝光/秒}}{10} = \frac{120}{10} = 12\%$$

参考额定功率图 A-195 150/180 Hz 三相 1.25 焦点：

在图的下面找到 3 秒一行。垂直移动到与 12% 的 DF 曲线交叉。水平移动到额定功率图的左侧，并记录 80 kW 的额定功率。

我们现在知道在例子给出的条件下，Cine 运行时每个脉冲可以有最大 80 kW 的额定功率。

kW = kV x mA。曝光的功率可以是放射成像和灯丝发射图允许的任何 mA 和 kV 组合。

Cine 额定功率图可用于 100% 阳极热容量。Cine 开始运行时热容量应该低于 70%。超过 100% 的阳极热容量将导致阳极磁道腐蚀，且很容易损坏射线管。

3 Ø 恒定电压

50/60 Hz

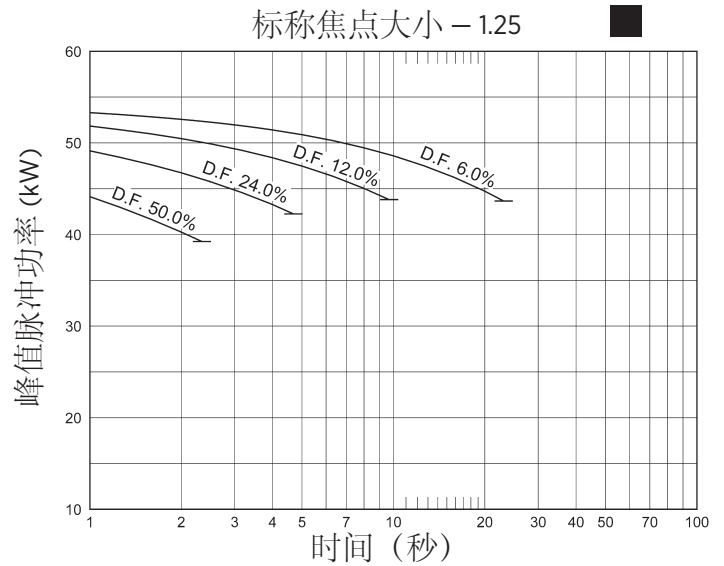
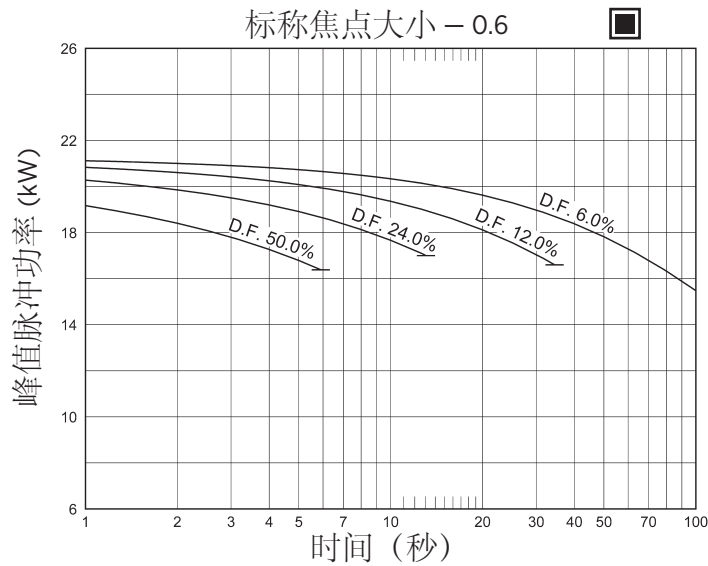

150/180 Hz

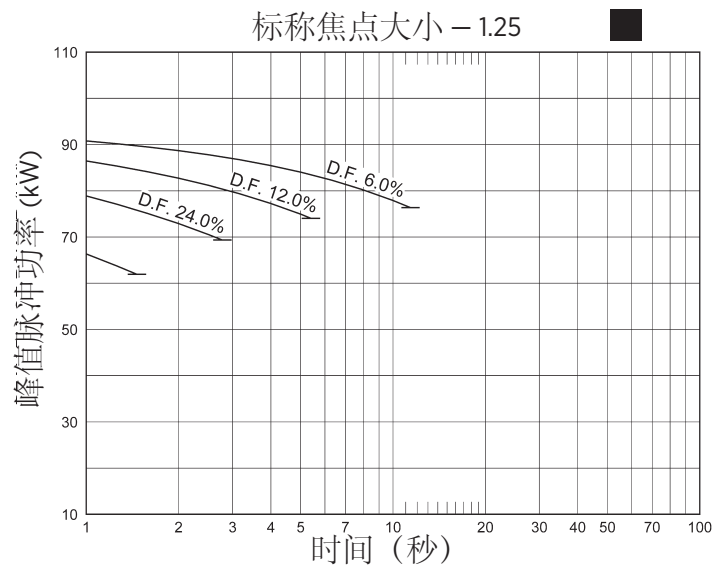
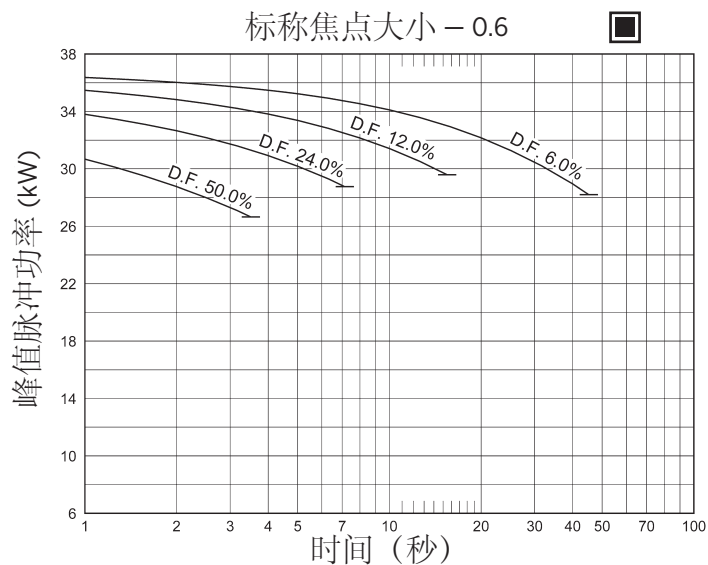

Nominal anode input power for the anode heat content 70%. IEC 60613

阳极热容量 70% 的标称阳极输入功率。IEC 60613

SERIAL LOAD RATINGS HOW TO USE SERIAL LOAD RATING CHARTS

General: Serial Radiography puts a severe demand on the x-ray tube due to the large number of exposures made in rapid succession. Intervals between exposures are fixed and so short that it is not possible for the anode track to cool to any extent during the exposure series. Therefore, the temperature of the anode track increases from exposure to exposure. The kW values used in the angiographic charts have been determined to prevent damage to the anode. The angiographic rating charts are usable to 100% anode heat storage. Exceeding 100% anode heat storage will cause anode track erosion with high risk of tube destruction.

Definition of Terms

Number of Exposures in Series: The number of exposures made in succession or the number of exposures made during one contrast injection.

Exposure Rate: The number of exposures made per second. For a series of exposures where the exposure rate changes, it must be assumed that all exposures will be made at the maximum rate. For example, if during a series 10 exposures will occur at one per second and 30 exposures at 4 per second use the kW ratings in the 40 exposure column at 4 per second rate.

Exposure Time: Time in seconds of each exposure.

USING THE CHARTS:

Select Correct Chart:

50/60 or 150/180 Hz
0.6 or 1.25 Focal Spot

Note: 150/180 Hz rotor speed recommended for all angiography.

Determine the number of exposures in Series: With cut film angiography the number of exposures are known, however in Digital Angiography the number of exposures commonly are not known. When determining the number of exposures, assume worst case or past history.

Note: Most angiographic x-ray tubes fail from under-estimating the number of exposures made in a series.

Determine kW of each exposure in Series: Referring to chart —find block under “Number of Exposures in Series” that is greater than or equal to expected number of exposures in Series. On left side directly opposite this block under “Exposure Rate per Second” column, select maximum rate per second that will be used for the exposure series. At the intersection of exposure rate and exposure time in seconds, find maximum kW allowed for each exposure.

kW = pkV x mA: The kW of the exposure can be any combination of mA and pkV allowed by the Radiographic and Filament Emission charts.

For Example: 80 pkV and 500 mA = 40 kW

Example: From chart A-195 150/180 Hz 3 Phase
1.25 Focal Spot, determine kW allowed with following known factors.
Maximum number of exposures 40
Exposure time .050 second (50 milliseconds)
Maximum Exposures per second 4

From chart find 40 exposure block. On left side directly opposite this block under “Exposure Rate per Second” column, select 4 exposures per second. Find .050 seconds at top of chart. At intersection of exposure rate line and exposure time, find 53.8 kW.

连续装载规定值 如何使用连续负载额定率图

概述：因为需要快速进行大量曝光，连续放射成像对 X 射线管提出了严格的要求。曝光的间隔是固定的，因为非常短，所以阳极磁道在连续曝光的过程中不可能冷却到任何程度。所以，阳极磁道的温度随着曝光次数的增加而升高。为了防止损坏阳极，血管造影图中使用的功率值经过了确认。血管造影额定功率图适用于 100% 的阳极热容量。超过 100% 的阳极热容量将导致阳极磁道腐蚀，且很容易损坏射线管。

术语定义

连续曝光次数：连续曝光次数或在一个造影剂注射期间进行的曝光次数。

曝光速度：每秒进行的曝光次数。对于曝光速度变化的连续曝光，必须假设所有曝光都将以最高的速度进行。例如，如果连续曝光时，10 次曝光将每秒发生一次，而 30 次的曝光每秒 4 次，则使用每秒 4 次速度时 40 次曝光栏中的额定功率。

曝光时间：每次曝光的时间（秒）。

使用图表：

选择正确的图表：

50/60 或 150/180 Hz

0.6 或 1.25 焦点

注释：所有血管造影建议使用 150/180 Hz 的阳极转速。

确定连续曝光次数：对于单张胶片血管造影术，曝光次数都是已知的，但是在数字化血管造影术中，曝光次数往往都是不知道的。确定曝光次数时，假定最坏的情况或根据以往的经验。

注释：大多数血管造影 X 射线管的故障是由于低估了连续曝光次数。

确定连续曝光中每次曝光的功率 (kW)：参考图，在“连续曝光次数”下找到大于等于期望的连续曝光次数的区域。在左侧直接面对这块区域的“每秒的曝光速度”栏中，选择将用于该曝光序列的每秒最高速度。在曝光速率和曝光时间（秒）的交叉点处，找到每次曝光允许的最大功率值 (kW)。

kW = pkV x mA：曝光的功率可以是放射成像和灯丝发射图表允许的 mA 与 pkV 的任一组合。

例如：80 pkV x 500 mA = 40 kW

例如：从图 A-195 150/180 Hz 3 相 1.25 焦点中，
用以下已知的系数确定允许的功率 (kW)。
最大曝光次数 40
曝光时间 0.050 秒 (50 毫秒)
每秒最大曝光次数 4

从图中找到 40 曝光区。在左侧正对这块的“每秒曝光速度”栏，选择每秒 4 次曝光。在图顶部找到 0.050 秒。在曝光速度行与曝光时间的交叉点处，找到 53.8 kW。

0.6 Focal Spot 3Ø 12 Degrees 50/60 Hz
0.6 焦点 3Ø 12 度 50/60 Hz

每秒曝光速度	TUBE 射线管负载 (kW), 作为该连续曝光中单独放射成像的曝光时间 (秒) 函数 3S															连续曝光次数
	0.010	0.020	0.030	0.040	0.050	0.060	0.080	0.100	0.120	0.140	0.160	0.180	0.200	0.225	0.250	
1	21.3	21.1	20.7	20.4	20.1	19.8	19.3	18.9	18.5	18.2	17.8	17.5	17.3	16.9	16.6	10
2	21.2	21.0	20.7	20.3	20.0	19.7	19.2	18.7	18.3	17.9	17.6	17.2	16.9	16.6	16.3	
3	21.2	21.0	20.6	20.2	19.9	19.6	19.0	18.5	18.1	17.7	17.3	17.0	—	—	—	
4	21.2	20.9	20.5	20.1	19.8	19.4	18.8	18.3	17.9	17.4	—	—	—	—	—	
8	21.1	20.7	20.2	19.8	19.3	19.0	—	—	—	—	—	—	—	—	—	
15	20.9	20.4	19.8	19.2	—	—	—	—	—	—	—	—	—	—	—	
30	20.6	19.9	—	—	—	—	—	—	—	—	—	—	—	—	—	
1	21.1	20.8	20.4	19.9	19.5	19.2	18.5	17.9	17.4	16.9	16.4	16.0	15.7	15.2	14.8	20
2	21.1	20.8	20.3	19.8	19.4	19.0	18.3	17.7	17.1	16.6	16.1	15.7	15.3	14.9	14.4	
3	21.1	20.7	20.2	19.7	19.2	18.8	18.1	17.4	16.9	16.3	15.9	15.4	—	—	—	
4	21.0	20.6	20.1	19.6	19.1	18.7	17.9	17.2	16.6	16.1	—	—	—	—	—	
8	20.9	20.4	19.7	19.1	18.6	18.1	—	—	—	—	—	—	—	—	—	
15	20.7	20.0	19.2	18.5	—	—	—	—	—	—	—	—	—	—	—	
30	20.3	19.3	—	—	—	—	—	—	—	—	—	—	—	—	—	
1	20.9	20.4	19.7	19.0	18.5	18.0	17.0	16.2	15.5	14.9	14.3	13.7	13.3	12.2	11.0	40
2	20.8	20.3	19.6	18.9	18.3	17.8	16.8	16.0	15.3	14.6	14.0	13.5	13.0	12.2	11.0	
3	20.8	20.2	19.5	18.8	18.2	17.6	16.6	15.8	15.0	14.3	13.7	13.2	—	—	—	
4	20.7	20.1	19.4	18.7	18.0	17.5	16.4	15.6	14.8	14.1	—	—	—	—	—	
8	20.6	19.8	19.0	18.2	17.5	16.9	—	—	—	—	—	—	—	—	—	
15	20.3	19.4	18.3	17.5	—	—	—	—	—	—	—	—	—	—	—	
30	19.9	18.6	—	—	—	—	—	—	—	—	—	—	—	—	—	
1	20.6	19.9	19.0	18.3	17.6	16.9	15.8	14.9	14.0	13.1	11.5	10.2	9.2	8.1	7.3	60
2	20.6	19.8	18.9	18.1	17.4	16.8	15.6	14.6	13.8	13.1	11.5	10.2	9.2	8.1	7.3	
3	20.5	19.7	18.8	18.0	17.3	16.6	15.4	14.4	13.6	12.8	11.5	10.2	—	—	—	
4	20.5	19.7	18.7	17.9	17.1	16.4	15.3	14.2	13.4	12.6	—	—	—	—	—	
8	20.3	19.4	18.3	17.4	16.6	15.9	—	—	—	—	—	—	—	—	—	
15	20.1	18.9	17.7	16.6	—	—	—	—	—	—	—	—	—	—	—	
30	19.6	18.0	—	—	—	—	—	—	—	—	—	—	—	—	—	
1	20.4	19.5	18.4	17.5	16.7	16.0	14.8	13.7	11.5	9.8	8.6	7.6	6.9	6.1	5.5	80
2	20.3	19.4	18.3	17.4	16.6	15.8	14.6	13.5	11.5	9.8	8.6	7.6	6.9	6.1	5.5	
3	20.3	19.3	18.2	17.3	16.4	15.7	14.4	13.3	11.5	9.8	8.6	7.6	—	—	—	
4	20.3	19.2	18.1	17.1	16.3	15.5	14.2	13.1	11.5	9.8	—	—	—	—	—	
8	20.1	18.9	17.7	16.7	15.8	15.0	—	—	—	—	—	—	—	—	—	
15	19.8	18.4	17.1	16.0	—	—	—	—	—	—	—	—	—	—	—	
30	19.3	17.5	—	—	—	—	—	—	—	—	—	—	—	—	—	
1	20.2	19.0	17.9	16.9	16.0	15.2	13.8	11.0	9.2	7.9	6.9	6.1	5.5	4.9	4.4	100
2	20.1	19.0	17.8	16.7	15.8	15.0	13.7	11.0	9.2	7.9	6.9	6.1	5.5	4.9	4.4	
3	20.1	18.9	17.7	16.6	15.7	14.9	13.5	11.0	9.2	7.9	6.9	6.1	—	—	—	
4	20.0	18.8	17.6	16.5	15.6	14.7	13.4	11.0	9.2	7.9	—	—	—	—	—	
8	19.8	18.5	17.2	16.0	15.1	14.2	—	—	—	—	—	—	—	—	—	
15	19.5	18.0	16.5	15.3	—	—	—	—	—	—	—	—	—	—	—	
30	19.0	17.1	—	—	—	—	—	—	—	—	—	—	—	—	—	
1	19.6	18.1	16.6	15.4	14.4	12.2	9.2	7.3	6.1	5.2	4.6	4.1	3.7	3.3	2.9	150
2	19.6	18.0	16.5	15.3	14.2	12.2	9.2	7.3	6.1	5.2	4.6	4.1	3.7	3.3	2.9	
3	19.5	17.9	16.4	15.2	14.1	12.2	9.2	7.3	6.1	5.2	4.6	4.1	—	—	—	
4	19.5	17.8	16.3	15.1	14.0	12.2	9.2	7.3	6.1	5.2	—	—	—	—	—	
8	19.3	17.5	16.0	14.6	13.6	12.2	—	—	—	—	—	—	—	—	—	
15	19.0	17.0	15.4	14.0	—	—	—	—	—	—	—	—	—	—	—	
30	18.4	16.2	—	—	—	—	—	—	—	—	—	—	—	—	—	

Note:
1. (kW) of Exposure Equals mA x kV.
For Example: 70 kV x 300 mA = 21 kW.
2. Exposures less than .010 seconds will have a kW rating same as .010 seconds.

注释:
1. 曝光功率 (kW) 等于 mA x kV。 例如: 70 kV x 300 mA = 21 kW。
2. 小于 0.010 秒的曝光将与 0.010 秒曝光具有相同的额定功率。

Nominal anode input power for the anode heat content 70%. IEC 60613

阳极热容量 70% 的标称阳极输入功率。 IEC 60613

0.6 Focal Spot 3Ø 12 Degrees 150/180 Hz
0.6 焦点 3Ø 12 度 150/180 Hz

每秒曝光速度	TUBE	射线管负载 (kW), 作为该连续曝光中单独放射成像的曝光时间 (秒) 函数														连续曝光次数
		0.010	0.020	0.030	0.040	0.050	0.060	0.080	0.100	0.120	0.140	0.160	0.180	0.200	0.225	
1	36.4	35.1	34.1	33.3	32.5	31.8	30.6	29.6	28.6	27.8	27.1	26.4	25.8	25.1	24.4	10
2	36.4	35.0	33.9	33.0	32.2	31.5	30.2	29.1	28.1	27.2	26.4	25.7	25.1	24.3	23.6	
3	36.3	34.8	33.7	32.8	31.9	31.1	29.8	28.6	27.6	26.7	25.9	25.1	—	—	—	
4	36.2	34.7	33.5	32.5	31.6	30.8	29.4	28.2	27.1	26.2	—	—	—	—	—	
8	35.9	34.1	32.8	31.6	30.6	29.6	—	—	—	—	—	—	—	—	—	
15	35.4	33.3	31.6	30.2	—	—	—	—	—	—	—	—	—	—	—	
30	34.6	31.9	—	—	—	—	—	—	—	—	—	—	—	—	—	
1	36.1	34.4	33.1	32.0	31.0	30.1	28.6	27.2	26.0	24.9	24.0	23.1	22.4	21.5	20.7	20
2	36.0	34.2	32.9	31.7	30.7	29.7	28.1	26.6	25.4	24.3	23.4	22.5	21.7	20.8	20.0	
3	35.9	34.1	32.6	31.4	30.3	29.3	27.6	26.1	24.9	23.8	22.8	21.9	—	—	—	
4	35.8	33.9	32.4	31.1	30.0	29.0	27.2	25.7	24.4	23.3	—	—	—	—	—	
8	35.4	33.2	31.5	30.0	28.8	27.7	—	—	—	—	—	—	—	—	—	
15	34.8	32.2	30.1	28.5	—	—	—	—	—	—	—	—	—	—	—	
30	33.7	30.4	—	—	—	—	—	—	—	—	—	—	—	—	—	
1	35.3	33.1	31.3	29.8	28.5	27.3	25.2	23.5	22.0	19.6	17.2	15.3	13.8	12.2	11.0	40
2	35.2	32.9	31.1	29.5	28.1	26.9	24.8	23.0	21.5	19.6	17.2	15.3	13.8	12.2	11.0	
3	35.1	32.7	30.8	29.2	27.8	26.5	24.4	22.6	21.1	19.6	17.2	15.3	—	—	—	
4	35.0	32.5	30.5	28.9	27.4	26.1	24.0	22.1	20.6	19.3	—	—	—	—	—	
8	34.5	31.8	29.6	27.8	26.2	24.8	—	—	—	—	—	—	—	—	—	
15	33.8	30.6	28.1	26.1	—	—	—	—	—	—	—	—	—	—	—	
30	32.6	28.7	—	—	—	—	—	—	—	—	—	—	—	—	—	
1	34.6	31.9	29.7	27.9	26.3	25.0	22.6	18.3	15.3	13.1	11.5	10.2	9.2	8.1	7.3	60
2	34.5	31.7	29.5	27.6	26.0	24.6	22.2	18.3	15.3	13.1	11.5	10.2	9.2	8.1	7.3	
3	34.4	31.5	29.2	27.3	25.7	24.2	21.9	18.3	15.3	13.1	11.5	10.2	—	—	—	
4	34.3	31.3	29.0	27.0	25.4	23.9	21.5	18.3	15.3	13.1	—	—	—	—	—	
8	33.8	30.5	28.0	25.9	24.2	22.7	—	—	—	—	—	—	—	—	—	
15	33.0	29.3	26.5	24.3	—	—	—	—	—	—	—	—	—	—	—	
30	31.7	27.3	—	—	—	—	—	—	—	—	—	—	—	—	—	
1	34.0	30.8	28.3	26.3	24.5	22.9	17.2	13.8	11.5	9.8	8.6	7.6	6.9	6.1	5.5	80
2	33.8	30.6	28.0	26.0	24.2	22.7	17.2	13.8	11.5	9.8	8.6	7.6	6.9	6.1	5.5	
3	33.7	30.4	27.8	25.7	23.9	22.4	17.2	13.8	11.5	9.8	8.6	7.6	—	—	—	
4	33.6	30.2	27.6	25.4	23.6	22.1	17.2	13.8	11.5	9.8	—	—	—	—	—	
8	33.1	29.4	26.6	24.4	22.5	20.9	—	—	—	—	—	—	—	—	—	
15	32.3	28.3	25.2	22.9	—	—	—	—	—	—	—	—	—	—	—	
30	31.0	26.3	—	—	—	—	—	—	—	—	—	—	—	—	—	
1	33.3	29.8	27.0	24.8	22.0	18.3	13.8	11.0	9.2	7.9	6.9	6.1	5.5	4.9	4.4	100
2	33.2	29.6	26.8	24.5	22.0	18.3	13.8	11.0	9.2	7.9	6.9	6.1	5.5	4.9	4.4	
3	33.1	29.4	26.5	24.2	22.0	18.3	13.8	11.0	9.2	7.9	6.9	6.1	—	—	—	
4	32.9	29.2	26.3	24.0	22.0	18.3	13.8	11.0	9.2	7.9	—	—	—	—	—	
8	32.5	28.4	25.4	23.0	21.1	18.3	—	—	—	—	—	—	—	—	—	
15	31.7	27.3	24.1	21.6	—	—	—	—	—	—	—	—	—	—	—	
30	30.3	25.3	—	—	—	—	—	—	—	—	—	—	—	—	—	
1	31.8	27.4	24.2	18.3	14.7	12.2	9.2	7.3	6.1	5.2	4.6	4.1	3.7	3.3	2.9	150
2	31.7	27.3	24.0	18.3	14.7	12.2	9.2	7.3	6.1	5.2	4.6	4.1	3.7	3.3	2.9	
3	31.6	27.1	23.8	18.3	14.7	12.2	9.2	7.3	6.1	5.2	4.6	4.1	—	—	—	
4	31.5	26.9	23.6	18.3	14.7	12.2	9.2	7.3	6.1	5.2	—	—	—	—	—	
8	31.0	26.2	22.9	18.3	14.7	12.2	—	—	—	—	—	—	—	—	—	
15	30.2	25.2	21.7	18.3	—	—	—	—	—	—	—	—	—	—	—	
30	28.9	23.3	—	—	—	—	—	—	—	—	—	—	—	—	—	

Note:
1. (kW) of Exposure Equals mA x kV.
For Example: 70 kV x 300 mA = 21 kW.
2. Exposures less than .010 seconds will have a kW rating same as .010 seconds.

注释:
1. 曝光功率 (kW) 等于 mA x kV。 例如: 70 kV x 300 mA = 21 kW。
2. 小于 0.010 秒的曝光将与 0.010 秒曝光具有相同的额定功率。

Nominal anode input power for the anode heat content 70%. IEC 60613

阳极热容量 70% 的标称阳极输入功率。 IEC 60613

1.25 Focal Spot 3Ø 12 Degrees 50/60 Hz
1.25 焦点 3Ø 12 度 50/60 Hz

每秒曝光速度	射线管负载 (kW), 作为该连续曝光中单独放射成像的曝光时间 (秒) 函数															连续曝光次数
	0.010	0.020	0.030	0.040	0.050	0.060	0.080	0.100	0.120	0.140	0.160	0.180	0.200	0.225	0.250	
1	56.0	55.0	53.2	51.7	50.3	49.0	46.7	44.8	43.0	41.4	40.0	38.6	37.4	36.0	34.7	10
2	55.8	54.6	52.7	51.0	49.5	48.1	45.7	43.6	41.8	40.1	38.6	37.2	35.9	34.5	33.2	
3	55.7	54.3	52.2	50.4	48.8	47.4	44.8	42.6	40.7	38.9	37.4	36.0	—	—	—	
4	55.5	54.0	51.8	49.9	48.2	46.7	44.0	41.7	39.7	37.9	—	—	—	—	—	
8	55.0	53.0	50.5	48.2	46.3	44.5	—	—	—	—	—	—	—	—	—	
15	54.3	51.7	48.8	46.2	—	—	—	—	—	—	—	—	—	—	—	
30	53.4	50.1	—	—	—	—	—	—	—	—	—	—	—	—	—	
1	55.1	53.3	50.8	48.7	46.8	45.1	42.1	39.5	37.3	35.3	33.6	30.6	27.5	24.4	22.0	20
2	54.9	52.8	50.3	48.0	46.0	44.2	41.0	38.4	36.1	34.1	32.4	30.6	27.5	24.4	22.0	
3	54.7	52.4	49.7	47.3	45.2	43.3	40.1	37.4	35.1	33.0	31.3	29.7	—	—	—	
4	54.5	52.0	49.2	46.7	44.5	42.6	39.2	36.4	34.1	32.1	—	—	—	—	—	
8	53.8	50.8	47.5	44.7	42.3	40.2	—	—	—	—	—	—	—	—	—	
15	52.8	49.1	45.3	42.2	—	—	—	—	—	—	—	—	—	—	—	
30	51.3	46.6	—	—	—	—	—	—	—	—	—	—	—	—	—	
1	53.4	50.2	46.7	43.8	41.2	39.0	34.4	27.5	22.9	19.6	17.2	15.3	13.8	12.2	11.0	40
2	53.2	49.7	46.1	43.1	40.5	38.2	34.4	27.5	22.9	19.6	17.2	15.3	13.8	12.2	11.0	
3	52.9	49.3	45.6	42.4	39.7	37.4	33.6	27.5	22.9	19.6	17.2	15.3	—	—	—	
4	52.7	48.9	45.1	41.8	39.1	36.7	32.8	27.5	22.9	19.6	—	—	—	—	—	
8	51.9	47.5	43.3	39.8	36.9	34.5	—	—	—	—	—	—	—	—	—	
15	50.7	45.5	40.9	37.2	—	—	—	—	—	—	—	—	—	—	—	
30	48.7	42.5	—	—	—	—	—	—	—	—	—	—	—	—	—	
1	51.9	47.5	43.3	39.8	36.7	30.6	22.9	18.3	15.3	13.1	11.5	10.2	9.2	8.1	7.3	60
2	51.6	47.0	42.7	39.2	36.2	30.6	22.9	18.3	15.3	13.1	11.5	10.2	9.2	8.1	7.3	
3	51.3	46.6	42.2	38.6	35.6	30.6	22.9	18.3	15.3	13.1	11.5	10.2	—	—	—	
4	51.1	46.2	41.7	38.0	35.0	30.6	22.9	18.3	15.3	13.1	—	—	—	—	—	
8	50.2	44.8	40.0	36.2	33.1	30.5	—	—	—	—	—	—	—	—	—	
15	48.9	42.8	37.7	33.7	—	—	—	—	—	—	—	—	—	—	—	
30	46.8	39.7	—	—	—	—	—	—	—	—	—	—	—	—	—	
1	50.4	45.0	40.3	34.4	27.5	22.9	17.2	13.8	11.5	9.8	8.6	7.6	6.9	6.1	5.5	80
2	50.1	44.6	39.8	34.4	27.5	22.9	17.2	13.8	11.5	9.8	8.6	7.6	6.9	6.1	5.5	
3	49.8	44.2	39.3	34.4	27.5	22.9	17.2	13.8	11.5	9.8	8.6	7.6	—	—	—	
4	49.6	43.8	38.8	34.4	27.5	22.9	17.2	13.8	11.5	9.8	—	—	—	—	—	
8	48.7	42.5	37.3	33.2	27.5	22.9	—	—	—	—	—	—	—	—	—	
15	47.4	40.5	35.1	31.0	—	—	—	—	—	—	—	—	—	—	—	
30	45.2	37.5	—	—	—	—	—	—	—	—	—	—	—	—	—	
1	49.0	42.9	36.7	27.5	22.0	18.3	13.8	11.0	9.2	7.9	6.9	6.1	5.5	4.9	4.4	100
2	48.7	42.4	36.7	27.5	22.0	18.3	13.8	11.0	9.2	7.9	6.9	6.1	5.5	4.9	4.4	
3	48.4	42.0	36.7	27.5	22.0	18.3	13.8	11.0	9.2	7.9	6.9	6.1	—	—	—	
4	48.2	41.7	36.4	27.5	22.0	18.3	13.8	11.0	9.2	7.9	—	—	—	—	—	
8	47.3	40.4	34.9	27.5	22.0	18.3	—	—	—	—	—	—	—	—	—	
15	46.0	38.5	32.9	27.5	—	—	—	—	—	—	—	—	—	—	—	
30	43.8	35.6	—	—	—	—	—	—	—	—	—	—	—	—	—	
1	45.8	36.7	24.4	18.3	14.7	12.2	9.2	7.3	6.1	5.2	4.6	4.1	3.7	3.3	2.9	150
2	45.6	36.7	24.4	18.3	14.7	12.2	9.2	7.3	6.1	5.2	4.6	4.1	3.7	3.3	2.9	
3	45.3	36.7	24.4	18.3	14.7	12.2	9.2	7.3	6.1	5.2	4.6	4.1	—	—	—	
4	45.1	36.7	24.4	18.3	14.7	12.2	9.2	7.3	6.1	5.2	—	—	—	—	—	
8	44.2	36.1	24.4	18.3	14.7	12.2	—	—	—	—	—	—	—	—	—	
15	43.0	34.5	24.4	18.3	—	—	—	—	—	—	—	—	—	—	—	
30	40.8	31.8	—	—	—	—	—	—	—	—	—	—	—	—	—	

Note:
1. (kW) of Exposure Equals mA x kV.
For Example: 70 kV x 300 mA = 21 kW.
2. Exposures less than .010 seconds will have a kW rating same as .010 seconds.

注释:
1. 曝光功率 (kW) 等于 mA x kV。 例如: 70 kV x 300 mA = 21 kW。
2. 小于 0.010 秒的曝光将与 0.010 秒曝光具有相同的额定功率。

Nominal anode input power for the anode heat content 70%. IEC 60613

阳极热容量 70% 的标称阳极输入功率。 IEC 60613

1.25 Focal Spot 3Ø 12 Degrees 150/180 Hz
1.25 焦点 3Ø 12 度 150/180 Hz

每秒曝光速度	TUBE 射线管负载 (kW), 作为该连续曝光中单独放射成像的曝光时间 (秒) 函数 ^{IS}															连续曝光次数
	0.010	0.020	0.030	0.040	0.050	0.060	0.080	0.100	0.120	0.140	0.160	0.180	0.200	0.225	0.250	
1	94.9	89.1	84.6	80.8	77.5	74.6	69.6	65.3	61.7	58.5	55.6	53.1	50.8	48.3	44.0	10
2	94.3	88.1	83.3	79.2	75.8	72.7	67.4	62.9	59.2	55.9	53.0	50.4	48.2	45.6	43.3	
3	93.8	87.2	82.0	77.8	74.1	70.9	65.4	60.8	57.0	53.6	50.8	48.2	—	—	—	
4	93.4	86.4	81.0	76.6	72.7	69.3	63.6	58.9	55.0	51.7	—	—	—	—	—	
8	91.8	83.8	77.7	72.7	68.4	64.7	—	—	—	—	—	—	—	—	—	
15	89.9	80.7	73.8	68.1	—	—	—	—	—	—	—	—	—	—	—	
30	87.5	76.8	—	—	—	—	—	—	—	—	—	—	—	—	—	
1	92.3	84.6	78.7	73.7	69.5	65.9	59.7	54.7	45.8	39.3	34.4	30.6	27.5	24.4	22.0	20
2	91.6	83.5	77.3	72.1	67.7	64.0	57.7	52.6	45.8	39.3	34.4	30.6	27.5	24.4	22.0	
3	91.0	82.4	75.9	70.6	66.1	62.2	55.8	50.7	45.8	39.3	34.4	30.6	—	—	—	
4	90.5	81.6	74.8	69.3	64.6	60.7	54.2	49.0	44.9	39.3	—	—	—	—	—	
8	88.5	78.5	71.0	65.0	60.1	55.9	—	—	—	—	—	—	—	—	—	
15	85.9	74.5	66.2	59.8	—	—	—	—	—	—	—	—	—	—	—	
30	82.1	68.9	—	—	—	—	—	—	—	—	—	—	—	—	—	
1	87.6	77.1	69.2	63.0	55.0	45.8	34.4	27.5	22.9	19.6	17.2	15.3	13.8	12.2	11.0	40
2	86.9	76.0	67.9	61.6	55.0	45.8	34.4	27.5	22.9	19.6	17.2	15.3	13.8	12.2	11.0	
3	86.2	74.9	66.7	60.3	55.0	45.8	34.4	27.5	22.9	19.6	17.2	15.3	—	—	—	
4	85.6	74.0	65.6	59.1	53.8	45.8	34.4	27.5	22.9	19.6	—	—	—	—	—	
8	83.5	70.9	62.0	55.2	49.8	45.5	—	—	—	—	—	—	—	—	—	
15	80.4	66.6	57.2	50.2	—	—	—	—	—	—	—	—	—	—	—	
30	75.7	60.4	—	—	—	—	—	—	—	—	—	—	—	—	—	
1	83.5	70.9	61.1	45.8	36.7	30.6	22.9	18.3	15.3	13.1	11.5	10.2	9.2	8.1	7.3	60
2	82.8	69.8	60.8	45.8	36.7	30.6	22.9	18.3	15.3	13.1	11.5	10.2	9.2	8.1	7.3	
3	82.1	68.9	59.7	45.8	36.7	30.6	22.9	18.3	15.3	13.1	11.5	10.2	—	—	—	
4	81.5	68.0	58.7	45.8	36.7	30.6	22.9	18.3	15.3	13.1	—	—	—	—	—	
8	79.3	65.0	55.4	45.8	36.7	30.6	—	—	—	—	—	—	—	—	—	
15	76.2	61.0	51.1	44.1	—	—	—	—	—	—	—	—	—	—	—	
30	71.2	54.9	—	—	—	—	—	—	—	—	—	—	—	—	—	
1	79.7	65.6	45.8	34.4	27.5	22.9	17.2	13.8	11.5	9.8	8.6	7.6	6.9	6.1	5.5	80
2	79.0	64.7	45.8	34.4	27.5	22.9	17.2	13.8	11.5	9.8	8.6	7.6	6.9	6.1	5.5	
3	78.4	63.8	45.8	34.4	27.5	22.9	17.2	13.8	11.5	9.8	8.6	7.6	—	—	—	
4	77.8	63.0	45.8	34.4	27.5	22.9	17.2	13.8	11.5	9.8	—	—	—	—	—	
8	75.6	60.2	45.8	34.4	27.5	22.9	—	—	—	—	—	—	—	—	—	
15	72.5	56.4	45.8	34.4	—	—	—	—	—	—	—	—	—	—	—	
30	67.6	50.7	—	—	—	—	—	—	—	—	—	—	—	—	—	
1	76.3	55.0	36.7	27.5	22.0	18.3	13.8	11.0	9.2	7.9	6.9	6.1	5.5	4.9	4.4	100
2	75.6	55.0	36.7	27.5	22.0	18.3	13.8	11.0	9.2	7.9	6.9	6.1	5.5	4.9	4.4	
3	75.0	55.0	36.7	27.5	22.0	18.3	13.8	11.0	9.2	7.9	6.9	6.1	—	—	—	
4	74.4	55.0	36.7	27.5	22.0	18.3	13.8	11.0	9.2	7.9	—	—	—	—	—	
8	72.3	55.0	36.7	27.5	22.0	18.3	—	—	—	—	—	—	—	—	—	
15	69.4	52.7	36.7	27.5	—	—	—	—	—	—	—	—	—	—	—	
30	64.5	47.3	—	—	—	—	—	—	—	—	—	—	—	—	—	
1	68.9	36.7	24.4	18.3	14.7	12.2	9.2	7.3	6.1	5.2	4.6	4.1	3.7	3.3	2.9	150
2	68.3	36.7	24.4	18.3	14.7	12.2	9.2	7.3	6.1	5.2	4.6	4.1	3.7	3.3	2.9	
3	67.7	36.7	24.4	18.3	14.7	12.2	9.2	7.3	6.1	5.2	4.6	4.1	—	—	—	
4	67.2	36.7	24.4	18.3	14.7	12.2	9.2	7.3	6.1	5.2	—	—	—	—	—	
8	65.4	36.7	24.4	18.3	14.7	12.2	—	—	—	—	—	—	—	—	—	
15	62.7	36.7	24.4	18.3	—	—	—	—	—	—	—	—	—	—	—	
30	58.2	36.7	—	—	—	—	—	—	—	—	—	—	—	—	—	

Note:
1. (kW) of Exposure Equals mA x kV.
For Example: 70 kV x 300 mA = 21 kW.
2. Exposures less than .010 seconds will have a kW rating same as .010 seconds.

注释:
1. 曝光功率 (kW) 等于 mA x kV。 例如: 70 kV x 300 mA = 21 kW。
2. 小于 0.010 秒的曝光将与 0.010 秒曝光具有相同的额定功率。

Nominal anode input power for the anode heat content 70%. IEC 60613

阳极热容量 70% 的标称阳极输入功率。 IEC 60613

3 Ø 全波

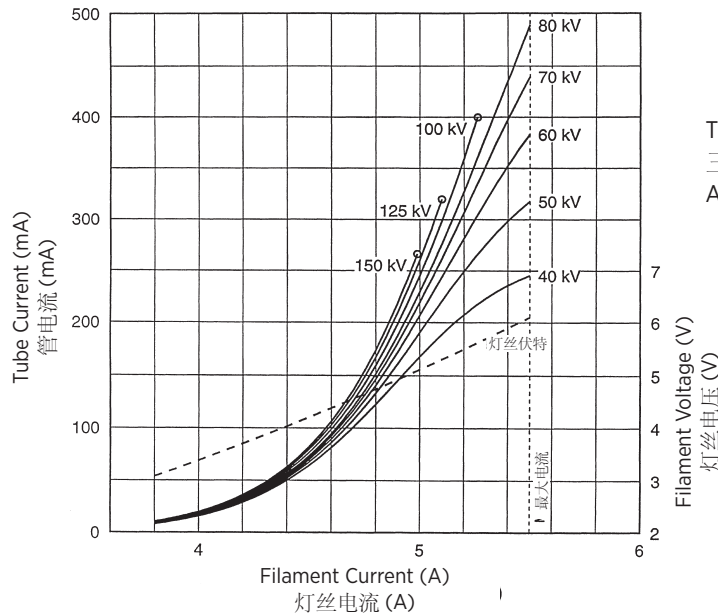

THREE PHASE EMISSION (± .15 A)
三相发射 (± .15 A)
A-195 0.6

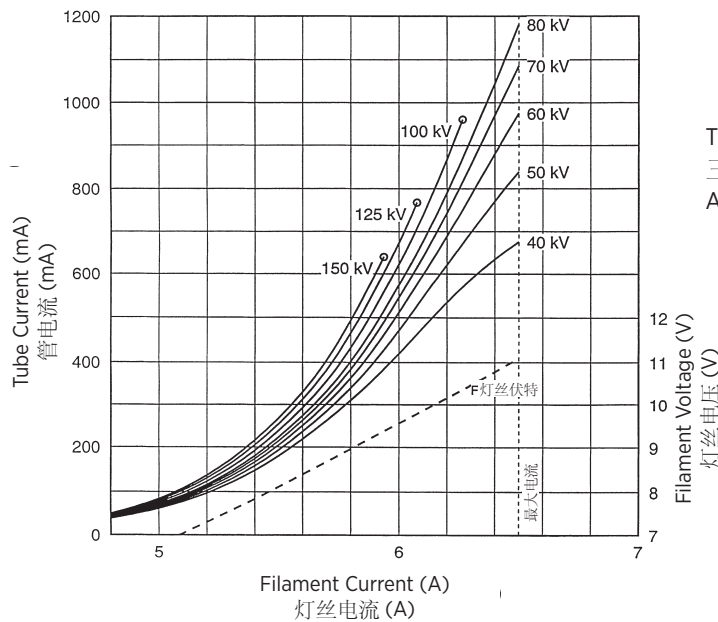

THREE PHASE EMISSION (± .15 A)
三相发射 (± .15 A)
A-195 1.25



Note: When using these emission curves for trial exposures, refer to the power rating curves shown for maximum kV, tube emission, filament current, exposure time, and target speed.

注释: 当为试验曝光使用这些辐射曲线时, 请同时参考额定功率曲线中与最大管电压、管电流、灯丝电流、曝光时间和阳极靶转速相关的限制条件。

ANODE HEATING AND COOLING CURVES
阳极加热与冷却曲线

