



GS-20724/B-220H X射线管组件由万睿视影像设备（中国）有限公司生产，作为医用X射线成像设备组件，用于X射线计算机断层成像设备（CT）。管组件由管套、X射线管、定子线圈、绝缘油和热交换器组成。有关产品维护、保养方法、禁忌症、注意事项、警示以及提示的信息见X射线成像诊断设备说明书。

Note: Document originally drafted in the English language.
注释：文件最初用英语起草。

Product Description

The GS-20724 is a 5.25" (133 mm) 150 kV, 1,429 kJ (2.0 MHU) maximum anode heat content, rotating anode insert. This insert is specifically designed for Weiheng Medical CT Scanners. The insert features a 7° tungsten-rhenium facing on molybdenum with a graphite backed target and is available with the following nominal focal spot:

0.7 x 0.8
1.2 x 1.4
IEC 60336

Loading Factor for slit focal:

Small - 120 kV, 100 mA
Large - 120 kV, 200 mA

Maximum Anode Cooling Rate:

4,000 W (5,600 HU/sec)

Continuous Anode Input Power:

3,000 W (4,200 HU/sec)

Nominal CT Anode Input Power:

Small - 26.5 kW IEC 60613:2010
Large - 42 kW IEC 60613:2010

Nominal CT Scan Power Index:

Small - 26.5 kW IEC 60613:2010
Large - 35.6 kW IEC 60613:2010

Reference Axis:

Perpendicular to port face.

This insert is intended for use in Varex Imaging B-220H housing.

产品说明

GS-20724 是一款具有 5.25" (133 mm) 靶盘, 150 kV, 1,429 kJ (2.0 MHU) 最大阳极热容量的旋转阳极 X 射线管芯。该管芯专门针对 Weiheng Medical CT 扫描仪而设计。该管芯的靶盘结构为 7° 靶角, 铼钨铝合金靶材, 石墨基底, 可提供下列尺寸的标称焦点:

0.7 x 0.8
1.2 x 1.4
IEC 60336

狭缝焦点的测量条件:

小焦点 - 120 kV, 100 mA
大焦点 - 120 kV, 200 mA

最大阳极冷却速率:

4,000 W (5,600 HU/sec)

连续阳极输入功率:

3,000 W (4,200 HU/sec)

标称CT阳极输入功率:

小焦点 - 26.5 kW IEC 60613:2010
大焦点 - 42 kW IEC 60613:2010

标称CT扫描功率指数

小焦点 - 26.5 kW IEC 60613:2010
大焦点 - 35.6 kW IEC 60613:2010

参考轴:

垂直于窗口面。

该管芯适用于 万睿视影像 B-220H 管套。

3 Ø 60 Hz 

0.7 x 0.8 Focal Spot 7°

0.7 x 0.8 焦点 7°

Volume scan time (seconds)	Maximum allowed tube current (mA) as a function of the following starting heat storage and tube voltages								
	Starting heat storage = 20 %			Starting heat storage = 40 %			Starting heat storage = 60 %		
	80 kV	100 kV	120 kV	80 kV	100 kV	120 kV	80 kV	100 kV	120 kV
4	235	185	155	235	185	155	235	185	155
10	235	185	155	235	185	155	235	185	155
20	235	185	155	235	185	155	235	185	155
30	235	185	155	235	185	155	200 (a)	160 (a)	130 (a)
40	235	185	155	235	185	155	155 (a)	125 (a)	105 (a)
50	235	185	155	195 (a)	155 (a)	130 (a)	130 (a)	100 (a)	85 (a)
60	220 (a)	175 (a)	145 (a)	165 (a)	130 (a)	110 (a)	110 (a)	90 (a)	75 (a)
80	170 (a)	135 (a)	110 (a)	125 (a)	100 (a)	85 (a)	90 (a)	70 (a)	60 (a)
90	150 (a)	120 (a)	100 (a)	115 (a)	90 (a)	75 (a)	80 (a)	65 (a)	55 (a)
100	135 (a)	110 (a)	90 (a)	105 (a)	85 (a)	70 (a)	75 (a)	60 (a)	50 (a)

3 Ø 180 Hz 

0.7 x 0.8 Focal Spot 7°

0.7 x 0.8 焦点 7°

Volume scan time (seconds)	Maximum allowed tube current (mA) as a function of the following starting heat storage and tube voltages								
	Starting heat storage = 20 %			Starting heat storage = 40 %			Starting heat storage = 60 %		
	80 kV	100 kV	120 kV	80 kV	100 kV	120 kV	80 kV	100 kV	120 kV
4	245 (c)	265 (c)	230	245 (c)	265 (c)	230	245 (c)	265 (c)	230
10	245 (c)	265 (c)	230	245 (c)	265 (c)	230	245 (c)	265 (c)	230
20	245 (c)	265 (c)	230	245 (c)	265 (c)	230	245 (c)	230 (a)	190 (a)
30	245 (c)	265 (c)	230	245 (c)	250 (a)	210 (a)	200 (a)	160 (a)	130 (a)
40	245 (c)	240 (b)	200 (b)	240 (a)	190 (a)	160 (a)	155 (a)	125 (a)	105 (a)
50	245 (c)	210 (a)	175 (a)	195 (a)	155 (a)	130 (a)	130 (a)	100 (a)	85 (a)
60	220 (a)	175 (a)	145 (a)	165 (a)	130 (a)	110 (a)	110 (a)	90 (a)	75 (a)
80	170 (a)	135 (a)	110 (a)	125 (a)	100 (a)	85 (a)	90 (a)	70 (a)	60 (a)
90	150 (a)	120 (a)	100 (a)	115 (a)	90 (a)	75 (a)	80 (a)	65 (a)	55 (a)
100	135 (a)	110 (a)	90 (a)	105 (a)	85 (a)	70 (a)	75 (a)	60 (a)	50 (a)

3 Ø 60 Hz 

1.2 x 1.4 Focal Spot 7°

1.2 x 1.4 焦点 7°

Volume scan time (seconds)	Maximum allowed tube current (mA) as a function of the following starting heat storage and tube voltages								
	Starting heat storage = 20 %			Starting heat storage = 40 %			Starting heat storage = 60 %		
	80 kV	100 kV	120 kV	80 kV	100 kV	120 kV	80 kV	100 kV	120 kV
4	495	395	330	495	395	330	495	395	330
10	450 (b)	360 (b)	300 (b)	450 (b)	360 (b)	300 (b)	450 (b)	360 (b)	300 (b)
20	450 (b)	360 (b)	300 (b)	450 (b)	360 (b)	300 (b)	290 (a)	230 (a)	190 (a)
30	375 (b)	300 (b)	250 (b)	315 (a)	250 (a)	210 (a)	200 (a)	160 (a)	130 (a)
40	300 (b)	240 (b)	200 (b)	240 (a)	190 (a)	160 (a)	155 (a)	125 (a)	105 (a)
50	260 (a)	210 (a)	175 (a)	195 (a)	155 (a)	130 (a)	130 (a)	100 (a)	85 (a)
60	220 (a)	175 (a)	145 (a)	165 (a)	130 (a)	110 (a)	110 (a)	90 (a)	75 (a)
80	170 (a)	135 (a)	110 (a)	125 (a)	100 (a)	85 (a)	90 (a)	70 (a)	60 (a)
90	150 (a)	120 (a)	100 (a)	115 (a)	90 (a)	75 (a)	80 (a)	65 (a)	55 (a)
100	135 (a)	110 (a)	90 (a)	105 (a)	85 (a)	70 (a)	75 (a)	60 (a)	50 (a)

3 Ø 180 Hz 

1.2 x 1.4 Focal Spot 7°

1.2 x 1.4 焦点 7°

Volume scan time (seconds)	Maximum allowed tube current (mA) as a function of the following starting heat storage and tube voltages								
	Starting heat storage = 20 %			Starting heat storage = 40 %			Starting heat storage = 60 %		
	80 kV	100 kV	120 kV	80 kV	100 kV	120 kV	80 kV	100 kV	120 kV
4	525 (b)	420 (b)	350 (b)	525 (b)	420 (b)	350 (b)	525 (b)	420 (b)	350 (b)
10	450 (b)	360 (b)	300 (b)	450 (b)	360 (b)	300 (b)	450 (b)	360 (b)	300 (b)
20	450 (b)	360 (b)	300 (b)	450 (b)	360 (b)	300 (b)	290 (a)	230 (a)	190 (a)
30	375 (b)	300 (b)	250 (b)	315 (a)	250 (a)	210 (a)	200 (a)	160 (a)	130 (a)
40	300 (b)	240 (b)	200 (b)	240 (a)	190 (a)	160 (a)	155 (a)	125 (a)	105 (a)
50	260 (a)	210 (a)	175 (a)	195 (a)	155 (a)	130 (a)	130 (a)	100 (a)	85 (a)
60	220 (a)	175 (a)	145 (a)	165 (a)	130 (a)	110 (a)	110 (a)	90 (a)	75 (a)
80	170 (a)	135 (a)	110 (a)	125 (a)	100 (a)	85 (a)	90 (a)	70 (a)	60 (a)
90	150 (a)	120 (a)	100 (a)	115 (a)	90 (a)	75 (a)	80 (a)	65 (a)	55 (a)
100	135 (a)	110 (a)	90 (a)	105 (a)	85 (a)	70 (a)	75 (a)	60 (a)	50 (a)

Note:
 1. Limits are based on maximum track rating except for the following codes:
 a - Limited by available heat storage.
 b - Limited by window heating.
 c - Limited by filament emission.
 2. H.S. = Heat Storage
 kV = Tube Voltage

注释
 1. 除如下所列规则外，限制均以最大轨道额定值为依据：
 a - 受有效热容量限制。
 b - 受窗口加热限制。
 c - 受灯丝放射限制。
 2. H.S. = 热容量
 kV = 管电压

Note:
 Rating charts reflect maximum tube performance. Tube operation is ultimately limited by system software.

注释
 额定值表反映最大管性能。管的工作状况最终受系统软件的限制。

3 Ø 

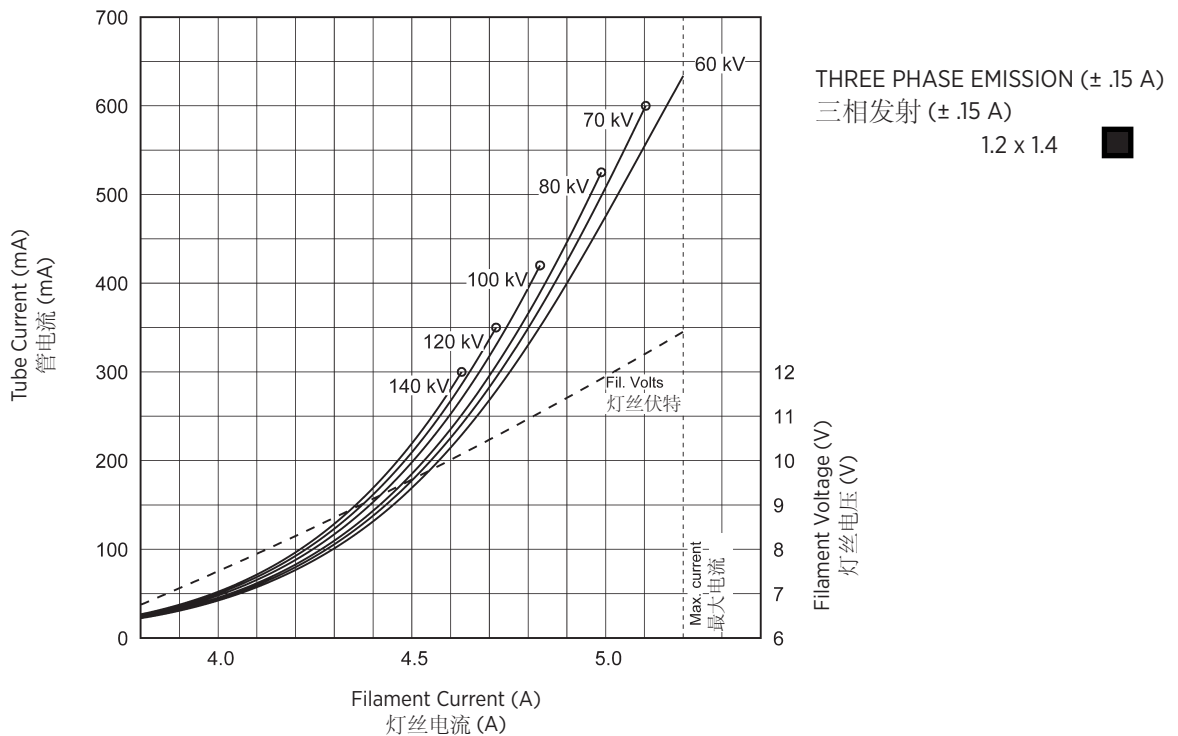
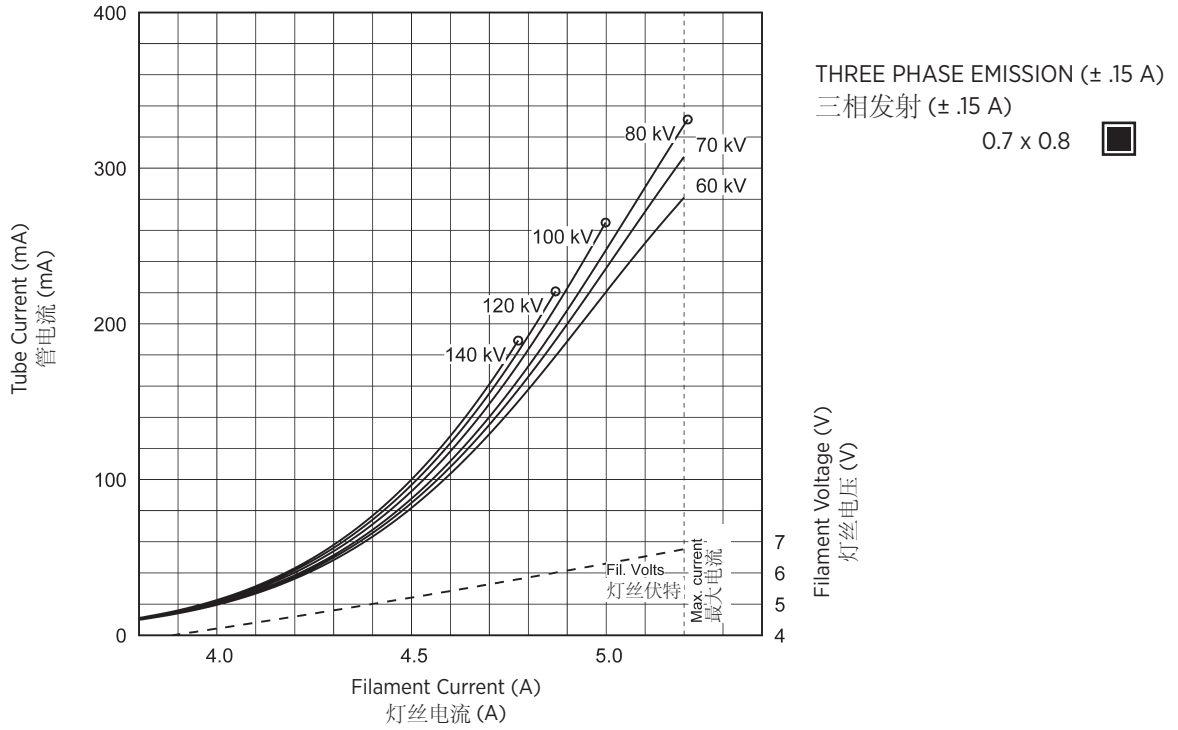

<u>Product Description</u>	
Maximum Peak Voltage	150 kV
Anode to Ground	75 kV
Cathode to Ground	75 kV
Maximum X-ray Tube Assembly Heat Content	3.1 MJ (4.3 MHU)
Maximum Housing Temperature	78°C
Nominal Continuous Input Power (Includes stator heat)	3.2 kW (4,480 HU/sec) IEC 60613:2010
Maximum Heat Exchanger Dissipation	5.0 kW (7,050 HU/sec)
Focal Point Position (Central Ray) Within 1mm (X, Y Direction from the center of radiation port.)	
X-Ray Tube Assembly	
Permanent filtration	1.0 mm Al IEC 60522
Loading Factors for Leakage Radiation	150 kV, 20 mA
High Voltage Cable Receptacles	Per IEC 60526
Ambient Air Temperature Limits for Operation	5°C to 40°C
Temperature Limits for Storage and Transport	-20°C to +75°C
Humidity	+10% to +90%
Atmospheric Pressure Range	70 kPa to 106 kPa
Weight - Housing	31.5 kg (69.4 lbs)
Heat Exchanger	16.3 kg (35.9 lbs)
IEC Classification	Class 1
Safety Devices: Thermal Switch	
Normally closed contact	Opening at 85°C ±3.9°C
Pressure Switch	
Normally Open contact	closes before 5.0 PSID Rising opens at 3.0 PSID ±0.2 PSID Falling
Filament Frequency Limits	50 Hz - 25 kHz
Power Supply	DC

<u>产品说明</u>	
最大峰值电压	150 kV
阳极到地	75 kV
阴极到地	75 kV
最大 X 射线管组件热含量	3.1 MJ (4.3 MHU)
最大管套温度	78°C
标称连续输入功率 (包括定子热量)	3.2 kW (4,480 HU/sec) IEC 60613:2010
交换器最大热耗散	5.0 kW (7,050 HU/sec)
焦点位置 (中心射线) 在 1 mm 内 (源于辐射端口中心的 X、Y 方向)	
X 射线管组件	
固有滤过	1.0 mm Al IEC 60522
泄漏辐射加载系数	150 kV, 20 mA
高压电缆插座	IEC 60526
环境气温工作限值	5°C ~ 40°C
存储与运输温度限值	-20°C ~ +75°C
湿度	+10% ~ +90%
大气压范围	70 kPa ~ 106 kPa
重量: 管套	31.5 kg (69.4 lbs)
热交换器	16.3 kg (35.9 lbs)
IEC 分级	1 类
安全性装置: 热控开关	
常闭接点	开启温度 85°C ±3.9°C
压力开关	
触点常开	在 5.0PSID 上升沿前关闭, 在 3.0PSID ± 0.2PSID 下降沿打开。
灯丝频率限值	50 Hz - 25 kHz
电源	直流

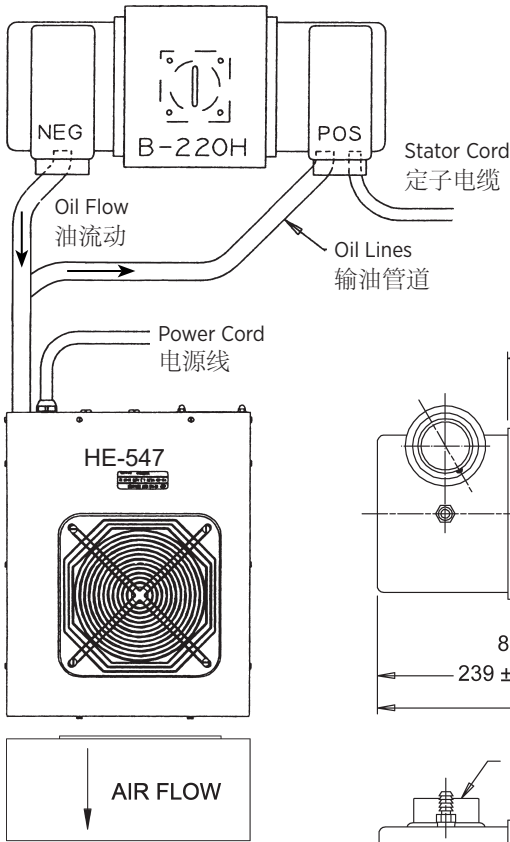

Dimensions are for reference only
维度是供仅参考

Dimensions are in millimeters
尺寸单位为毫米

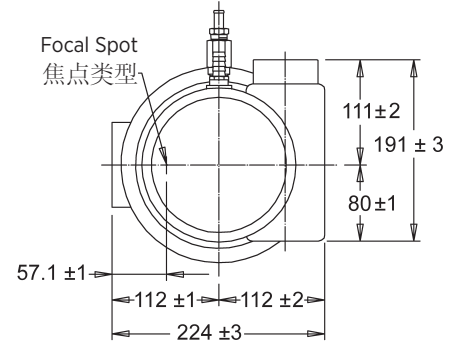
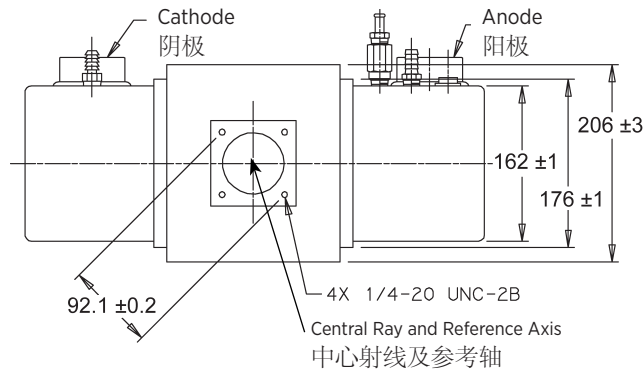
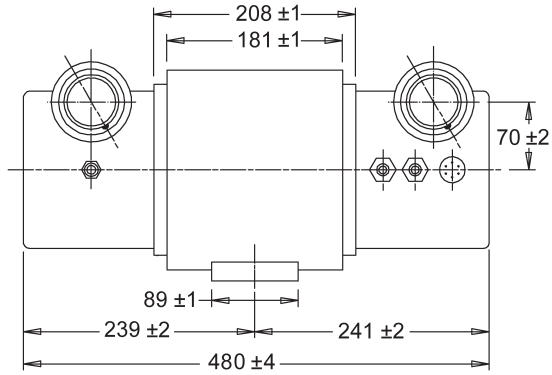

HE-547

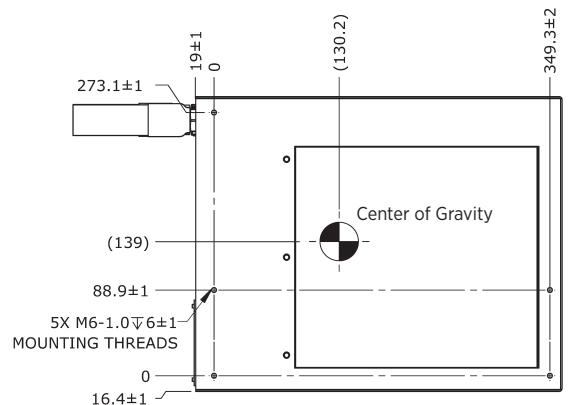
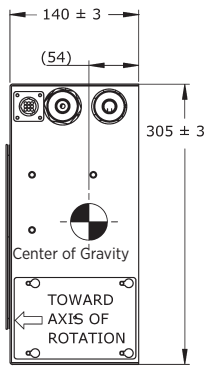
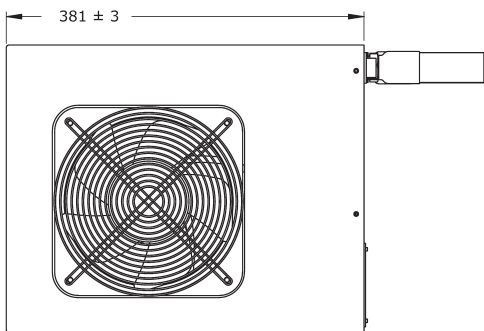
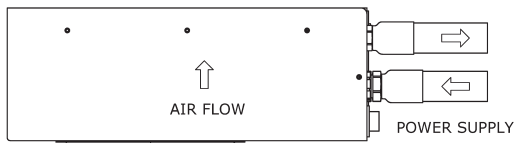

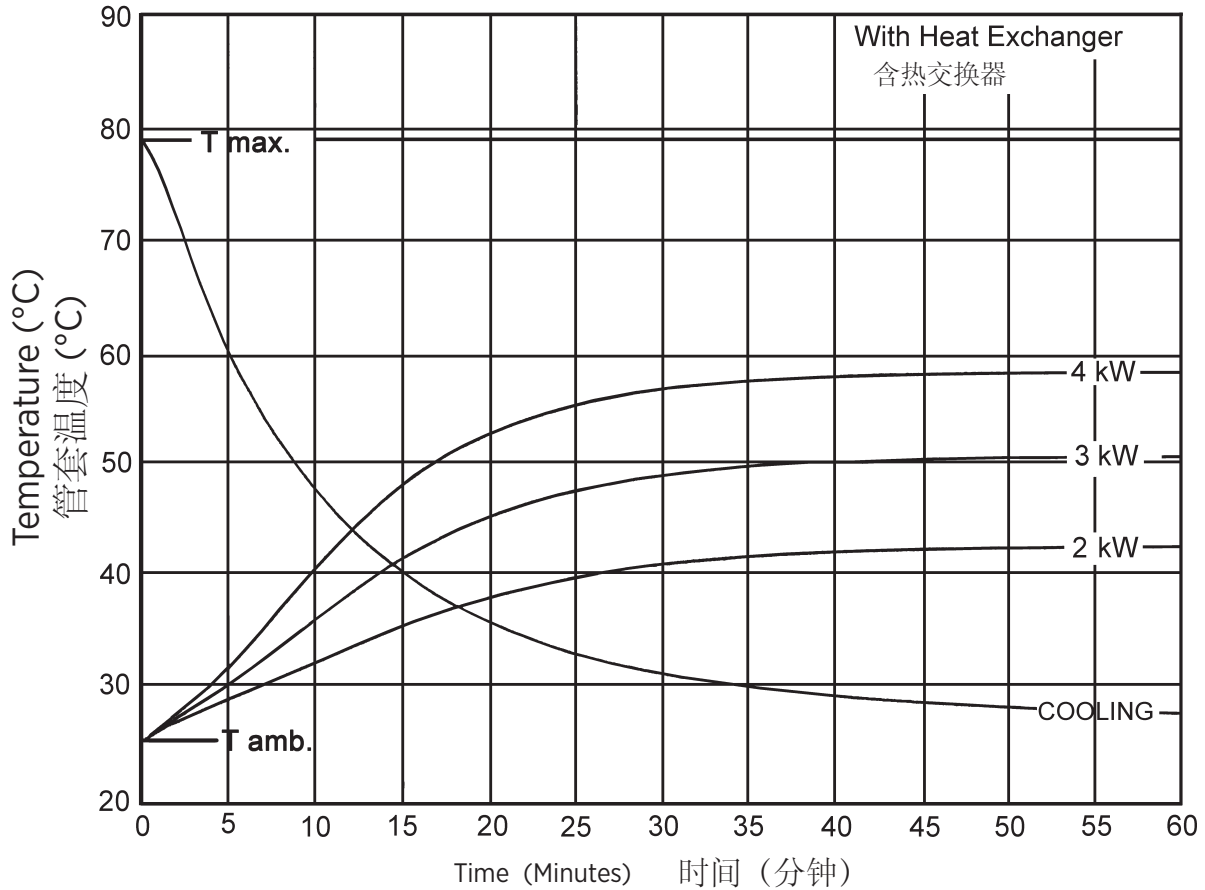
X-Ray Tube Housing Assembly Heating and Cooling
 X射线管组件加热/冷却曲线

Note:

- Heat input into housing includes all power sources; tube, filament, stator and circulating pump.
- Heating curves based on no restrictions to air flow through heat exchanger, or natural convection around tube housing assembly.
- Heating and cooling curves reflect maximum tube performance. Tube operation is ultimately limited by system software control.

注释:

- 输入外壳的热量包括所有电源;管,灯丝,定子和循环泵。
- 加热曲线基于对通过热交换器的空气流动没有限制,或管壳体组件周围的自然对流。
- 加热与冷却曲线反映了管的最高性能。管的工作状况最终受系统软件控制的限制。

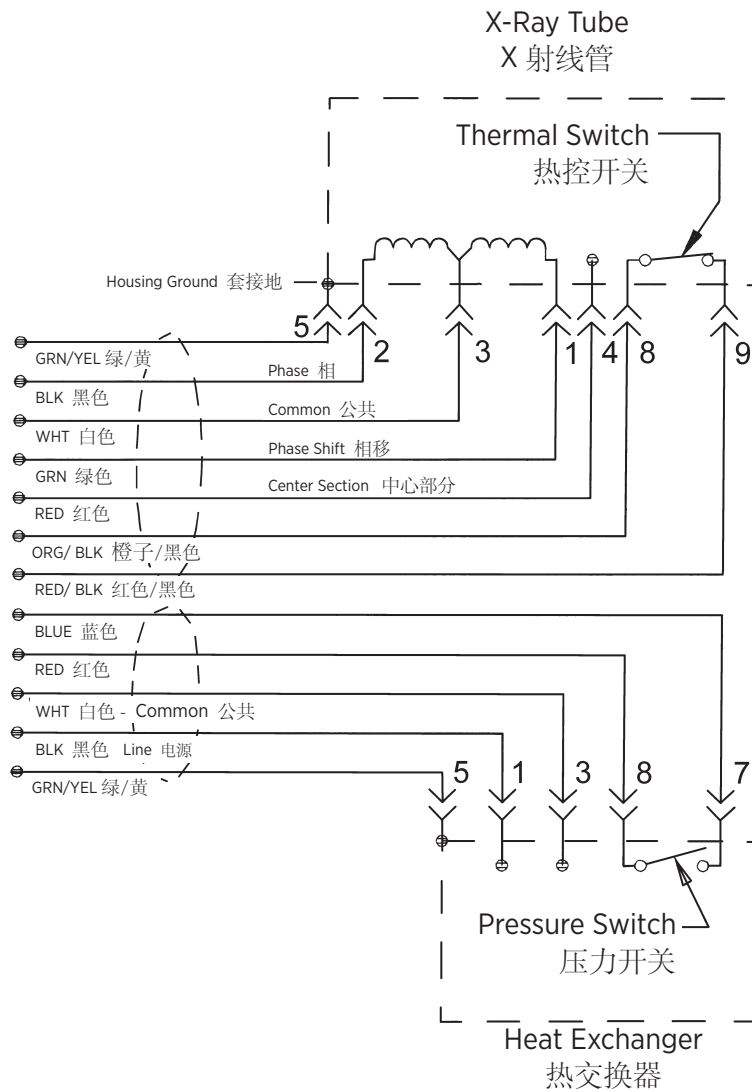
Stator - Wiring Diagram
定子—连线图



Wire Color 导线颜色	Description 描述
1 Green 绿色	Phase Shift 相移
2 Black 黑色	Phase 相
3 White 白色	Common 公共
4 Red 红色	Center Section 中心部分
5 Green/Yellow 绿色/黄色	Housing Ground 管套接地
8 Orange/Black 橙子/黑色	Thermal Switch 热控开关
9 Red/Black 红色/黑色	Thermal Switch 热控开关

Stator Drive Frequency 定子驱动频率	RPM
50 Hz	2800 - 3000
60 Hz	3400 - 3600
150 Hz	8500 - 9000
180 Hz	9500 - 10,800

Stator Type: "R"		
Stator Coil Resistance:		
Black to White	14 Ohms	±15%
Green to White	46 Ohms	±15%
Starter Voltage:		
	Start	Run
50/60 Hz	222 VAC	72 VAC
150/180 Hz	464 VAC	127 VAC
Time to Full Speed:		
50/60 Hz	0 - 2700 RPM	8.5 Sec.
150/180 Hz	0 - 8000 RPM	8.5 Sec.
X-Ray Tube Assembly:		
GS-20724/B-220H	IEC 60601-2-28	

定子的类型: "R" 定子		
定子线圈电阻:		
黑色到白色	14.0 Ω	±15%
绿色到白色	46.0 Ω	±15%
启动器电压:		
	启动	运行
50/60 Hz	222 VAC	72 VAC
150/180 Hz	464 VAC	127 VAC
达到全速的时间:		
50/60 Hz	0 - 2700 U/min	8.5 Sec
150/180 Hz	0 - 8000 U/min	8.5 Sec
X 射线管组件:		
GS-20724/B-220H	IEC 60601-2-28	

Heating and Cooling Curves
阳极加热与冷却曲线

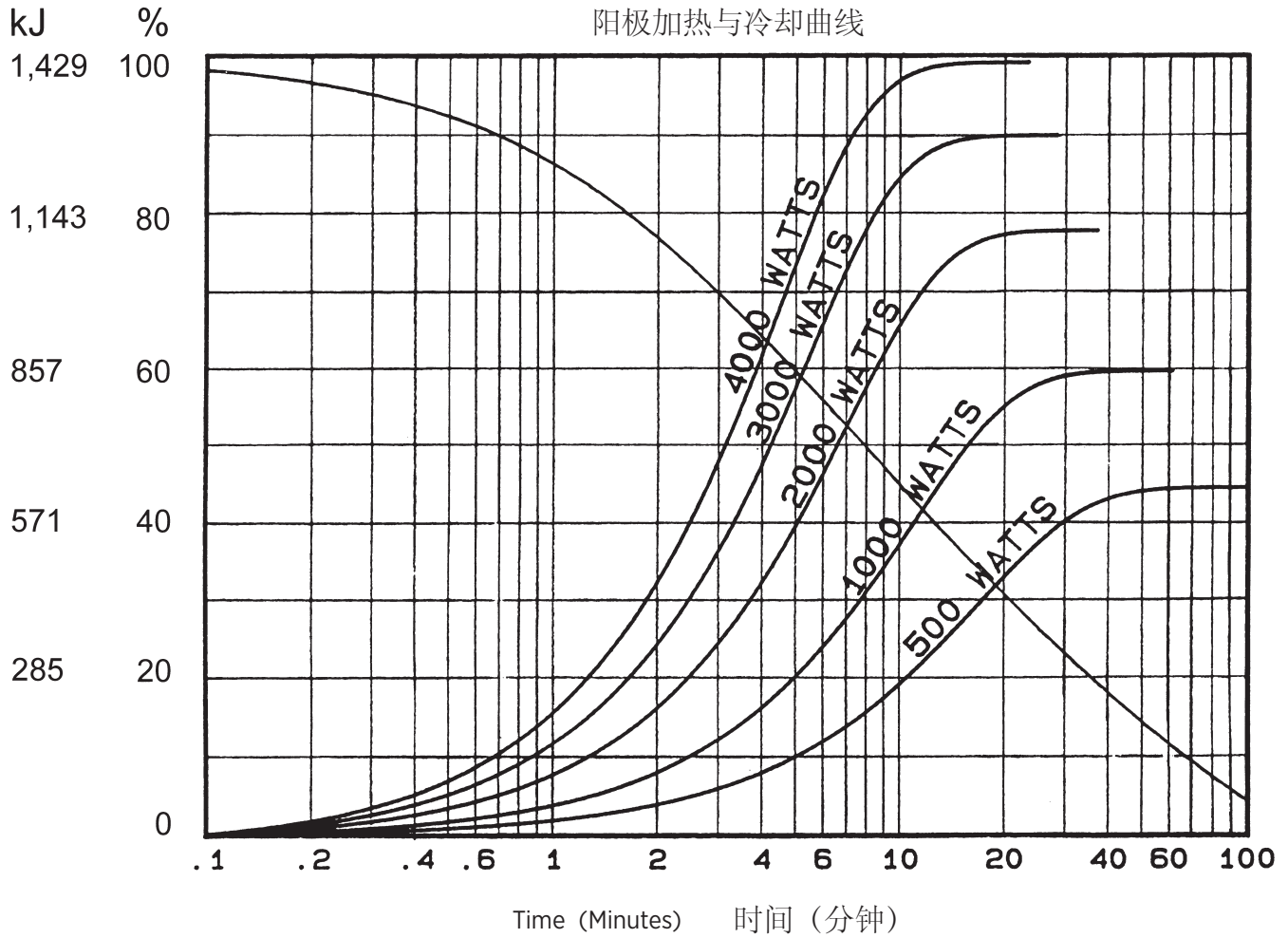

Note:
Heating and cooling curves reflect maximum tube performance. Tube operation is ultimately limited by system software control.

注释:
加热与冷却曲线反映了管的最高性能。管的工作状况最终受系统软件控制的限制。