



GS-30723/B-240H X射线管组件由万睿视影像设备（中国）有限公司生产，作为医用X射线成像设备组件，用于X射线计算机体层成像设备（CT）。管组件由管套、X射线管、定子线圈、绝缘油和热交换器组成。有关产品维护、保养方法、禁忌症、注意事项、警示以及提示的信息见X射线成像诊断设备说明书。

Note: Document originally drafted in the English language.
注释：文件最初用英语起草。

Product Description

The GS-30723 is a 5.5" (140 mm) 150 kV, 2.5 MJ (3.5 MHU) maximum anode heat content, rotating anode insert. This insert is specifically designed for Sinovision CT Scanners. The insert features a 7° tungsten-rhenium facing on molybdenum with a graphite backed target and is available with the following nominal focal spot:

- 0.7 x 0.8
- 1.2 x 1.4
- IEC 60336

Loading Factor for slit focal:
Small - 120 kV, 100 mA
Large - 120 kV, 200 mA

Maximum Anode Cooling Rate:
8,750 W (12,250 HU/sec)

Continuous Anode Input Power:
3,500 W (4,900 HU/sec)

Nominal CT Anode Input Power:
Small - 29 kW IEC 60613:2010
Large - 48 kW IEC 60613:2010

Nominal CT Scan Power Index:
Small - 29 kW IEC 60613:2010
Large - 43 kW IEC 60613:2010

Reference Axis:
Perpendicular to port face.

This insert is intended for use in Varex Imaging B-240H housing.

产品说明

GS-30723 是一款具有 5.5" (140 mm) 靶盘, 150 kV, 2.5 MJ (3.5 MHU) 最大阳极热容量的旋转阳极 X 射线管芯。该管芯专门针对 Sinovision CT 扫描仪而设计。该管芯的靶盘结构为 7° 靶角, 铼钨钼合金靶材, 石墨基底, 可提供下列尺寸的标称焦点:

- 0.7 x 0.8
- 1.2 x 1.4
- IEC 60336

狭缝焦点的测量条件:
小焦点 - 120 kV, 100 mA
大焦点 - 120 kV, 200 mA

最大阳极冷却速率:
8,750 W (12,250 HU/sec)

连续阳极输入功率:
3,500 W (4,900 HU/sec)

标称CT阳极输入功率:
小焦点 - 29 kW IEC 60613:2010
大焦点 - 48 kW IEC 60613:2010

标称CT扫描功率指数
小焦点 - 29 kW IEC 60613:2010
大焦点 - 43 kW IEC 60613:2010

基准轴:
垂直于窗口面。

该管芯适用于 万睿视影像 B-240H 管套。

3 Ø 60 Hz
 0.7 x 0.8 Focal Spot 7°
 0.7 x 0.8 焦点 7°



Volume scan time (seconds)	Maximum allowed tube current (mA) as a function of the following starting heat storage and tube voltages								
	Starting heat storage = 20 %			Starting heat storage = 40 %			Starting heat storage = 60 %		
	80 kV	100 kV	120 kV	80 kV	100 kV	120 kV	80 kV	100 kV	120 kV
4	255	205	170	255	205	170	255	205	170
10	255	205	170	255	205	170	255	205	170
20	255	205	170	255	205	170	255	205	170
30	255	205	170	255	205	170	255	205	170
40	255	205	170	255	205	170	220 (a)	175 (a)	145 (a)
50	255	205	170	255	205	170	185 (a)	145 (a)	120 (a)
60	255	205	170	235 (a)	190 (a)	155 (a)	155 (a)	125 (a)	105 (a)
80	245 (a)	195 (a)	160 (a)	180 (a)	145 (a)	120 (a)	125 (a)	100 (a)	80 (a)
90	220 (a)	175 (a)	145 (a)	165 (a)	130 (a)	110 (a)	115 (a)	90 (a)	75 (a)
100	195 (a)	155 (a)	130 (a)	150 (a)	120 (a)	100 (a)	105 (a)	85 (a)	70 (a)

3 Ø 180 Hz
 0.7 x 0.8 Focal Spot 7°
 0.7 x 0.8 焦点 7°



Volume scan time (seconds)	Maximum allowed tube current (mA) as a function of the following starting heat storage and tube voltages								
	Starting heat storage = 20 %			Starting heat storage = 40 %			Starting heat storage = 60 %		
	80 kV	100 kV	120 kV	80 kV	100 kV	120 kV	80 kV	100 kV	120 kV
4	285 (c)	300 (c)	250	285 (c)	300 (c)	250	285 (c)	300 (c)	250
10	285 (c)	300 (c)	250	285 (c)	300 (c)	250	285 (c)	300 (c)	250
20	285 (c)	300 (c)	250	285 (c)	300 (c)	250	285 (c)	300 (c)	250
30	285 (c)	300 (c)	250	285 (c)	300 (c)	250	285 (c)	230 (a)	190 (a)
40	285 (c)	295	245	285 (c)	275 (a)	230 (a)	220 (a)	175 (a)	145 (a)
50	285 (c)	280	235	280 (a)	225 (a)	185 (a)	185 (a)	145 (a)	120 (a)
60	285 (c)	255 (a)	210 (a)	235 (a)	190 (a)	155 (a)	155 (a)	125 (a)	105 (a)
80	245 (a)	195 (a)	160 (a)	180 (a)	145 (a)	120 (a)	125 (a)	100 (a)	80 (a)
90	220 (a)	175 (a)	145 (a)	165 (a)	130 (a)	110 (a)	115 (a)	90 (a)	75 (a)
100	195 (a)	155 (a)	130 (a)	150 (a)	120 (a)	100 (a)	105 (a)	85 (a)	70 (a)

3 Ø 60 Hz
 1.2 x 1.4 Focal Spot 7°
 1.2 x 1.4 焦点 7°



Volume scan time (seconds)	Maximum allowed tube current (mA) as a function of the following starting heat storage and tube voltages								
	Starting heat storage = 20 %			Starting heat storage = 40 %			Starting heat storage = 60 %		
	80 kV	100 kV	120 kV	80 kV	100 kV	120 kV	80 kV	100 kV	120 kV
4	500	400	330	500	400	330	500	400	330
10	500	400	330	500	400	330	500	400	330
20	500	400	330	500	400	330	420 (a)	335 (a)	280 (a)
30	450 (b)	360 (b)	300 (b)	450 (b)	360 (b)	300 (b)	285 (a)	230 (a)	190 (a)
40	375 (b)	300 (b)	250 (b)	345 (a)	275 (a)	230 (a)	220 (a)	175 (a)	145 (a)
50	375 (b)	300 (b)	250 (b)	280 (a)	225 (a)	185 (a)	185 (a)	145 (a)	120 (a)
60	320 (a)	255 (a)	210 (a)	235 (a)	190 (a)	155 (a)	155 (a)	125 (a)	105 (a)
80	245 (a)	195 (a)	160 (a)	180 (a)	145 (a)	120 (a)	125 (a)	100 (a)	80 (a)
90	220 (a)	175 (a)	145 (a)	165 (a)	130 (a)	110 (a)	115 (a)	90 (a)	75 (a)
100	195 (a)	155 (a)	130 (a)	150 (a)	120 (a)	100 (a)	105 (a)	85 (a)	70 (a)

3 Ø 180 Hz
 1.2 x 1.4 Focal Spot 7°
 1.2 x 1.4 焦点 7°



Volume scan time (seconds)	Maximum allowed tube current (mA) as a function of the following starting heat storage and tube voltages								
	Starting heat storage = 20 %			Starting heat storage = 40 %			Starting heat storage = 60 %		
	80 kV	100 kV	120 kV	80 kV	100 kV	120 kV	80 kV	100 kV	120 kV
4	590 (c)	480 (b)	400 (b)	590 (c)	480 (b)	400 (b)	590 (c)	480 (b)	400 (b)
10	525 (b)	420 (b)	350 (b)	525 (b)	420 (b)	350 (b)	525 (b)	420 (b)	350 (b)
20	525 (b)	420 (b)	350 (b)	525 (b)	420 (b)	350 (b)	420 (a)	335 (a)	280 (a)
30	450 (b)	360 (b)	300 (b)	450 (b)	360 (b)	300 (b)	285 (a)	230 (a)	190 (a)
40	375 (b)	300 (b)	250 (b)	345 (a)	275 (a)	230 (a)	220 (a)	175 (a)	145 (a)
50	375 (b)	300 (b)	250 (b)	280 (a)	225 (a)	185 (a)	185 (a)	145 (a)	120 (a)
60	320 (a)	255 (a)	210 (a)	235 (a)	190 (a)	155 (a)	155 (a)	125 (a)	105 (a)
80	245 (a)	195 (a)	160 (a)	180 (a)	145 (a)	120 (a)	125 (a)	100 (a)	80 (a)
90	220 (a)	175 (a)	145 (a)	165 (a)	130 (a)	110 (a)	115 (a)	90 (a)	75 (a)
100	195 (a)	155 (a)	130 (a)	150 (a)	120 (a)	100 (a)	105 (a)	85 (a)	70 (a)

Note:
 1. Limits are based on maximum track rating except for the following codes:
 a - Limited by available heat storage.
 b - Limited by window heating.
 c - Limited by filament emission.
 2. H.S. = Heat Storage
 kV = Tube Voltage

注释
 1. 除如下所列规则外，限制均以最大轨道额定值为依据：
 a - 受有效热容量限制。
 b - 受窗口加热限制。
 c - 受灯丝放射限制。
 2. H.S. = 热容量
 kV = 管电压

Note:
 Rating charts reflect maximum tube performance. Tube operation is ultimately limited by system software.

注释
 额定值表反映最大管性能。管的工作状况最终受系统软件的限制。

3 Ø

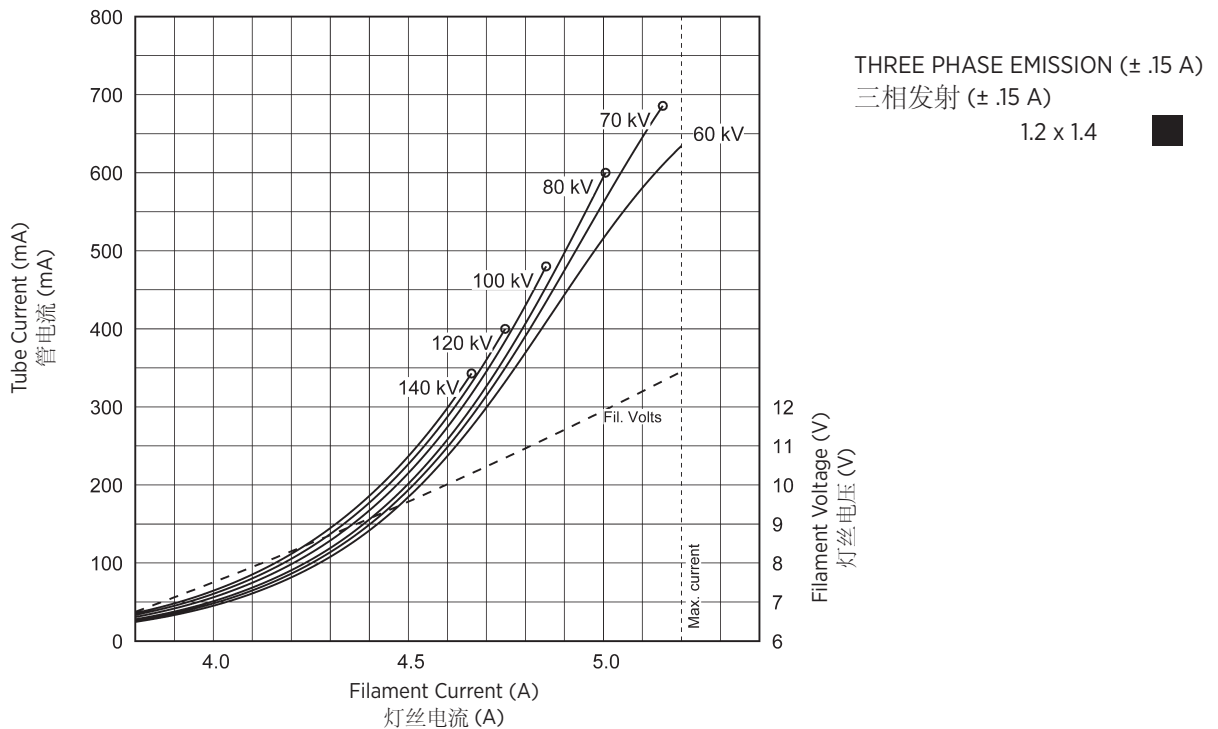
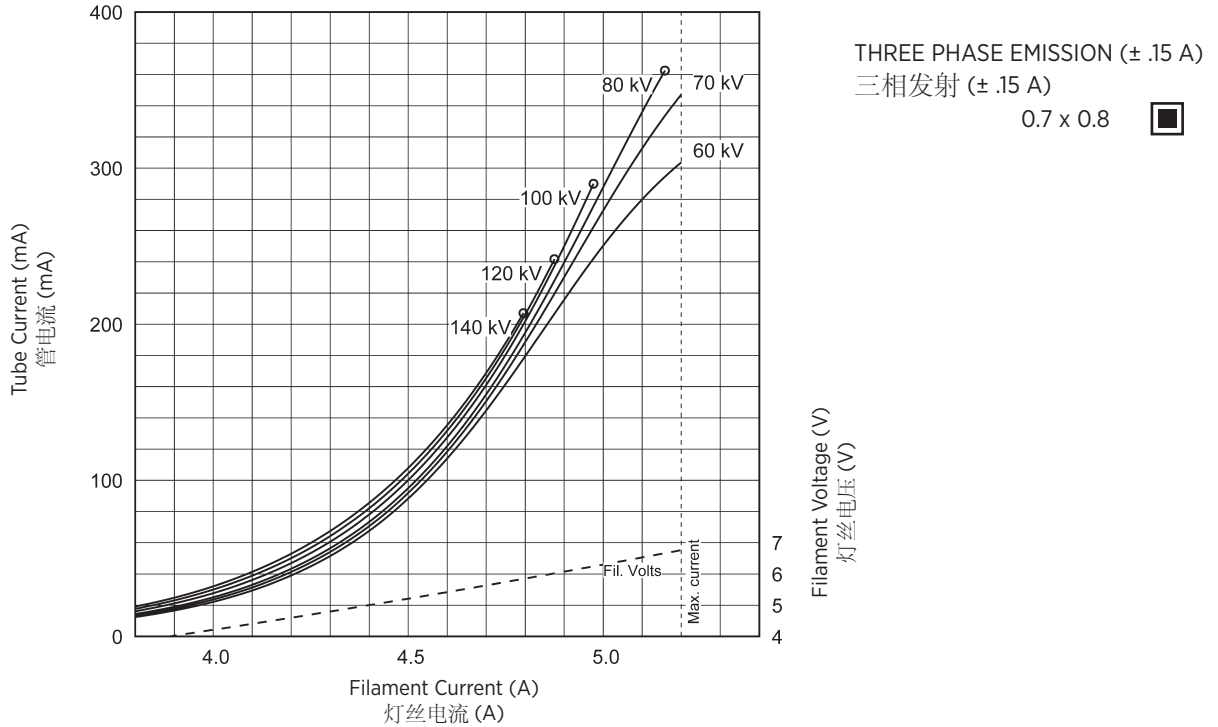

<u>Product Description</u>	<u>产品说明</u>
Maximum Peak Voltage 150 kV	最大峰值电压 150 kV
Anode to Ground 75 kV	阳极到地 75 kV
Cathode to Ground 75 kV	阴极到地 75 kV
Maximum X-ray Tube Assembly Heat Content ... 3.8 MJ (5.2 MHU)	最大 X 射线管组件热含量 3.8 MJ (5.2 MHU)
Nominal Continuous Input Power (max. housing temperature 78°C) (Includes stator heat) 3.7 kW (5.18 kHU/sec) IEC 60613:2010	标称连续输入功率 (最大管套温度78°C) (包括定子热量) 3.7 kW (5.18 kHU/sec) IEC 60613:2010
Maximum Heat Exchanger Dissipation 5.0 kW (7.0 kHU/sec)	交换器最大热耗散 5.0 kW (7.0 kHU/sec)
Focal Point Position (Central Ray) Within 1mm (X, Y Direction from the center of radiation port.)	焦点位置 (中心射线) 在 1 mm 内 (源于辐射端口中心的 X、Y 方向)
X-Ray Tube Assembly Permanent filtration 1.0 mm Al IEC 60522	X 射线管组件 固有滤过 1.0 mm Al IEC 60522
Loading Factors for Leakage Radiation 150 kV, 23 mA	泄漏辐射加载系数 150 kV, 23 mA
High Voltage Cable Receptacles Per IEC 60526	高压电缆插座 Per IEC 60526
Ambient Air Temperature Limits for Operation 5°C to 40°C	环境气温工作限值 5°C ~ 40°C
Temperature Limits for Storage and Transport -20°C to +75°C	存储与运输温度限值 -20°C ~ +75°C
Humidity +10% to +90%	湿度 +10% ~ +90%
Atmospheric Pressure Range 70 kPa to 106 kPa	大气压范围 70 kPa ~ 106 kPa
Weight: Housing 33.1 kg (73 lbs)	重量: 管套 33.1 kg (73 lbs)
Heat Exchanger 16.3 kg (35.9 lbs)	热交换器 16.3 kg (35.9 lbs)
IEC Classification Class 1	IEC 分级 1 类
Safety Devices: (Internal) Thermal Switch Normally Closed Contact Opening at 85°C ±3.9°C	安全性装置: (内部) 热控开关 常闭接点 开启温度 85°C ±3.9°C
Pressure Switch Normally Open contact closes before 5.0 PSID Rising opens at 3.0 PSID ±0.2 PSID Falling	压力开关 触点常开 在5.0PSID上升沿前关闭, 在3.0 PSID+0.2 PSID下降沿打开。
Filament Frequency Limits 50 HZ - 25 KHZ	灯丝频率限值 50 HZ - 25 KHZ
Power Supply DC	电源 直流

Dimensions are for reference only
维度是供仅参考

Dimensions are in millimeters
尺寸单位为毫米

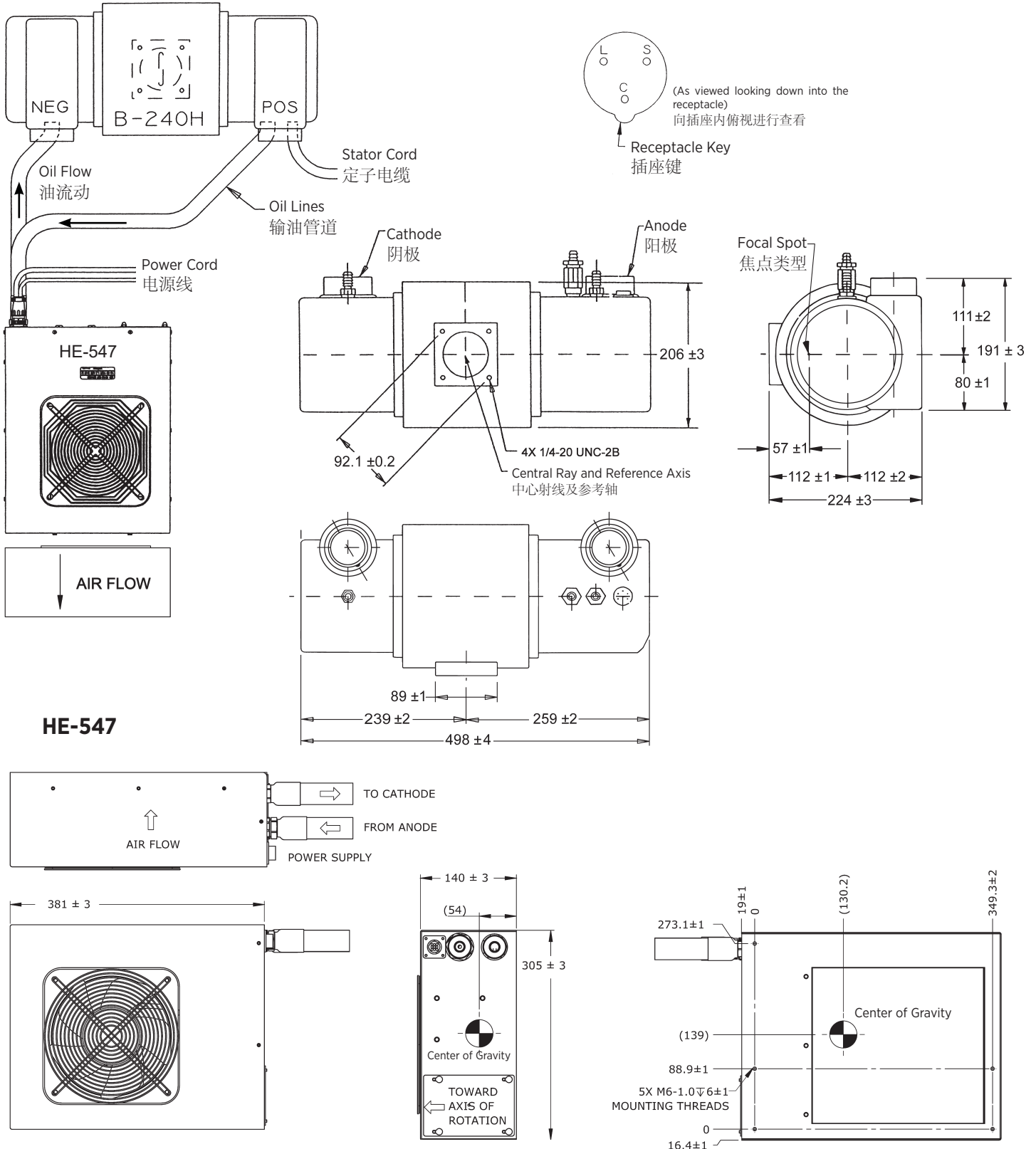

X-Ray Tube Housing Assembly Heating and Cooling
X射线管组件加热/冷却曲线

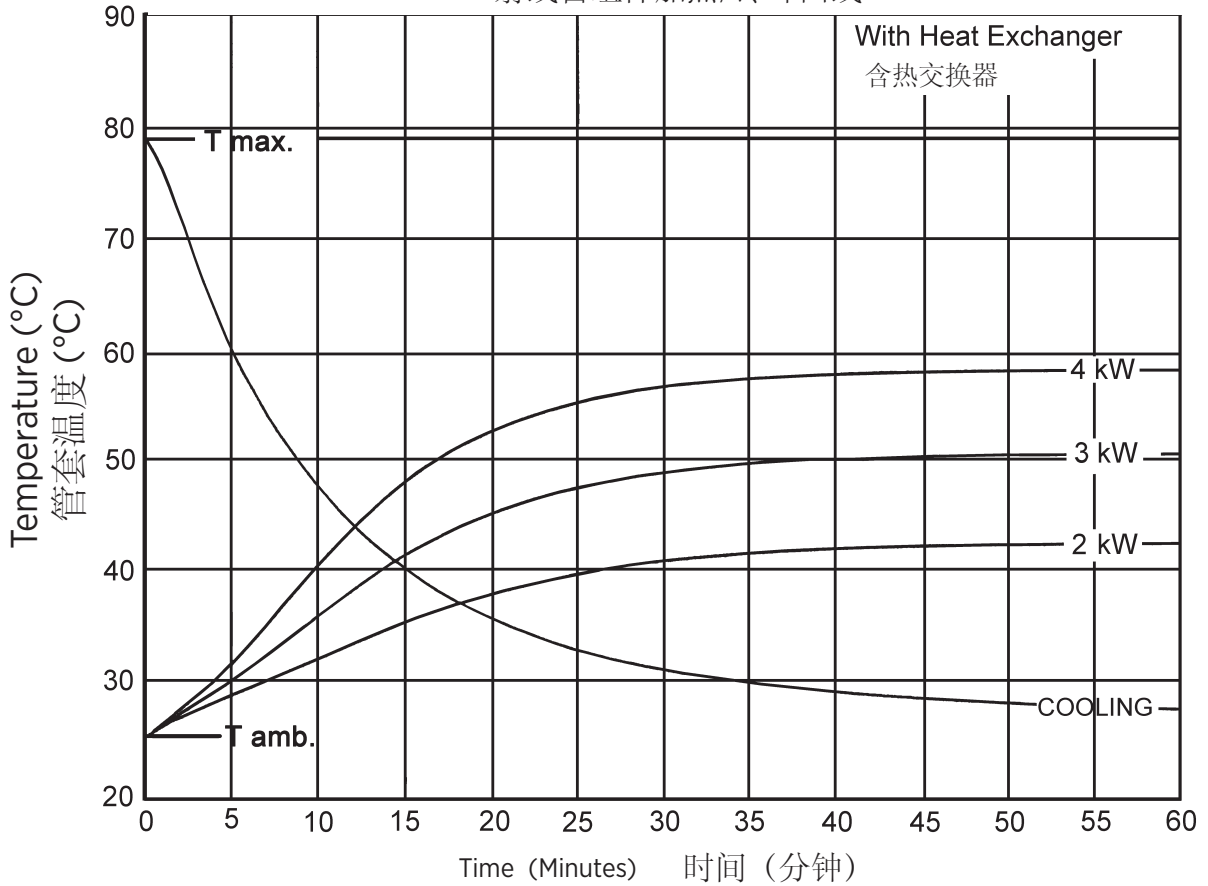

Note:
1. Heat inputs into housing include tube power, filament power, and stator power.
2. Heating curves based on no restrictions of natural convection around tube housing assembly.
3. Heating and cooling curves reflect maximum tube performance. Tube operation is ultimately limited by system software control.

注释:
1. 向管套的热量输入包括管功率、灯丝功率和定子功率。
2. 加热曲线以管套组件周围无自然对流的限制为根据。
3. 加热与冷却曲线反映了管的最高性能。管的工作状况最终受系统软件控制的限制。

Stator - Wiring Diagram 定子 - 连线图

Stator Ratings and Characteristics 定子额定值及特征

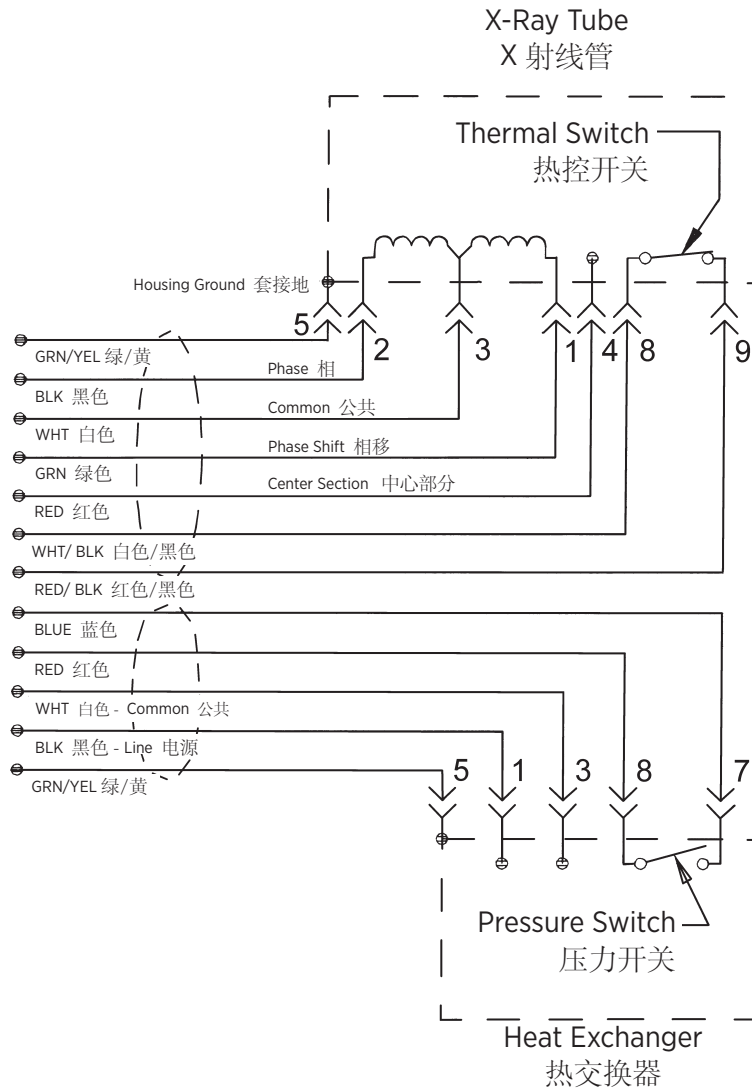

Wire Color 导线颜色	Description 描述
1 Green 绿色	Phase Shift 相移
2 Black 黑色	Phase 相
3 White 白色	Common 公共
4 Red 红色	Center Section 中心部分
5 Green/Yellow 绿色/黄色	Housing Ground 管套接地
8 White/Black 白色/黑色	Thermal Switch 热控开关
9 Red/Black 红色/黑色	Thermal Switch 热控开关

Stator Drive Frequency 定子驱动频率	RPM
50 Hz	2800 - 3000
60 Hz	3400 - 3600
150 Hz	8500 - 9000
180 Hz	9500 - 10,800

Stator Type: "R"	
Stator Coil Resistance:	
Black to White	14 Ohms ±15%
Green to White	46 Ohms ±15%
Starter Voltage:	
	Start Run
50/60 Hz	200 VAC 80 VAC
150/180 Hz	470 VAC 140 VAC
Time to Full Speed:	
50/60 Hz	0 - 3000 RPM 9.6 Sec.
150/180 Hz	0 - 8000 RPM 9.6 Sec.
X-Ray Tube Assembly:	
GS-30723/B-240H	IEC 60601-2-28

定子的类型: "R" 定子	
定子线圈电阻:	
黑色到白色	14.0 Ohms ±15%
绿色到白色	46.0 Ohms ±15%
启动器电压:	
	启动 运行
50/60 Hz	200 VAC 80 VAC
150/180 Hz	470 VAC 140 VAC
达到全速的时间:	
50/60 Hz	0 - 3000 RPM 9.6 Sec.
150/180 Hz	0 - 8000 RPM 9.6 Sec.
X射线管组件:	
GS-30723/B-240H	IEC 60601-2-28

Anode Heating and Cooling Curves

阳极加热与冷却曲线

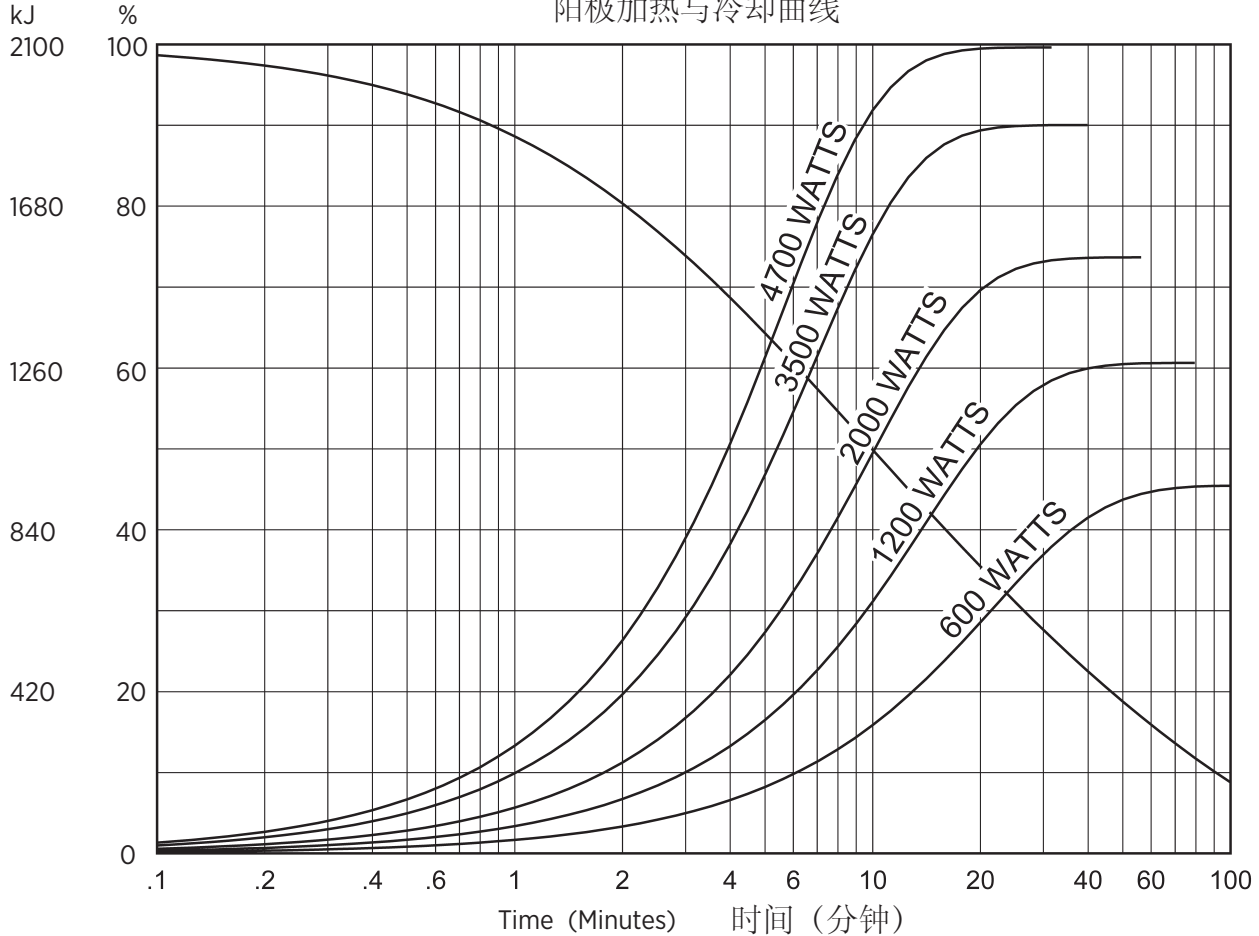

Note:
Heating and cooling curves reflect maximum tube performance. Tube operation is ultimately limited by system software control.

注释:
加热与冷却曲线反映了管的最高性能。管的工作状况最终受系统软件控制的限制。

Manufactured by Varex Imaging Corporation
由万睿视影像有限公司生产